



We are committed to the supply of all types of substrate wafers to the microelectronics industry

U3 Type Crystal

Features

- U3 typical 11.0x4.6x10.7mm standard footprint.
- High stability and Long-term stability.
- Resistance welding for hermetical seal.
- Tight tolerance 10 ppm available.
- Lead Free and RoHS compliant



ORDERING GUIDANCE

Product Type	Oscillation Mode	Calibration Tolerance (ppm)	Temperature Stability (ppm)	Operation Temp Range (°C)	Load Capacitance (pF)	Frequency (MHz)
Code: Meaning	Code: Meaning	Code: Meaning	Code: Meaning	Code: Meaning	Code: Meaning	
U3:	1: Fund 3: 3 rd OT 5: 5 th OT	A: ±10 B: ±15 C: ±20 D: ±30 F: ±50 G: ±5 H: ±25 XX: Special	1: ±10 2: ±15 3: ±20 4: ±30 5: ±50 6: ±100 7: ±5 8: ±3 9: ±25 00: Special	A: -10~+60 B: 0~+70 C: -20~+70 D: -40~+85 E: -55~+125 F: -10~+70 G: -40~+60 H: 0~+60 I: -20~+60 J: -40~+105 K: -40~+70 L: -40~+125	0: Series XX: CL Value In pF	XXX.XXXXXX
Ordering example: U3-1D4C18-20.000000MHz HC-49/UT Fund ±30ppm ±30ppm/-20~+70°C 18pF 20.000000MHz						
Note: If any other requirements are needed, they should be specified in customers' order.						

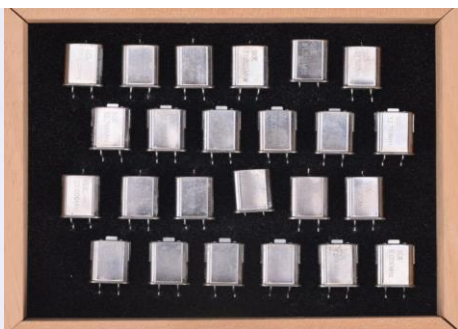
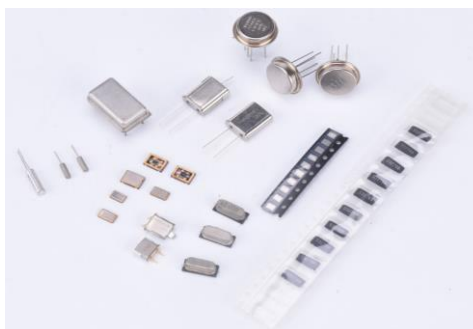

HANGZHOU FREQCONTROL ELECTRONIC TECHNOLOGY LTD.

Head office : # 1106, Crystal International Business Center(CIBC), No.198
Wuxing Rd ,Qianjiang new city Hangzhou, P.R.China Post code: 310006
TEL: 0086-571-85803723 85803731 85803732 FAX: 0086-571-85803724
E-mail: sales@csimc-freqcontrol.com thwu@mail.hz.zj.cn





We are committed to the supply of all types of substrate wafers to the microelectronics industry

Electrical Specification Resistance(ESR)

Equivalent Series

Storage Temp. Range	-55°C to +125°C	Frequency (MHz)	Mode	Max ESR (Ohms)
Drive Level(DL)	100uW typ., 500uW	10.000 – 15.999	Fund	30
Shunt Capacitance(C0)	7.0pF Max.	16.000 – 35.000	Fund	20
Insulation Resistance(IR)	500MΩ Min. @ 100V DC	25.000 – 100.000	3 rd O/T	40
Aging	±3ppm/year	60.000 – 79.999	5 th O/T	80
		80.000 – 150.000	5 th O/T	60

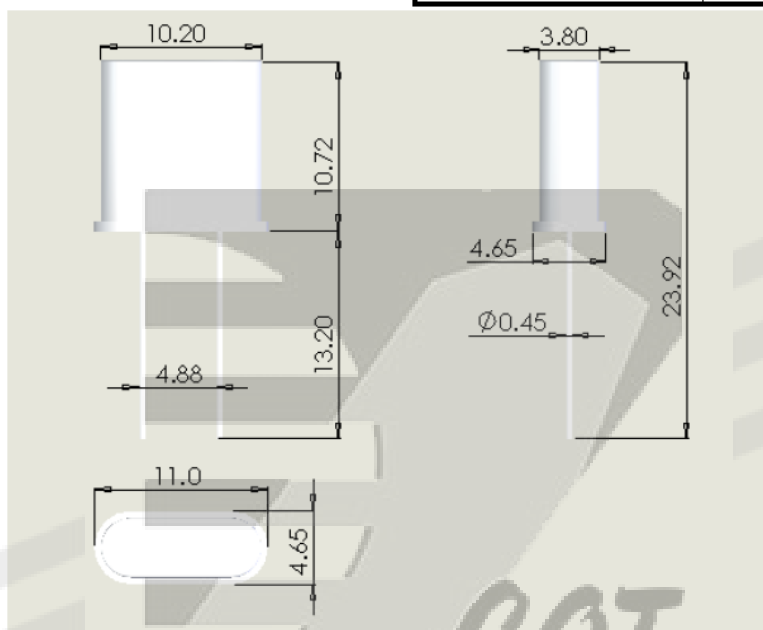

CHINA QUARTZ TECHNOLOGY

HANGZHOU FREQCONTROL ELECTRONIC TECHNOLOGY LTD.

Head office : # 1106, Crystal International Business Center(CIBC), No.198
 Wuxing Rd ,Qianjiang new city Hangzhou, P.R.China Post code: 310006
 TEL: 0086-571-85803723 85803731 85803732 FAX: 0086-571-85803724
 E-mail: sales@csimc-freqcontrol.com thwu@mail.hz.zj.cn

