



We are committed to the supply of all types of substrate wafers to the microelectronics industry

U2 Type Crystal

Features

- U2 typical 18.2x11.0x5.5mm standard footprint.
- High stability and Long-term stability.
- Resistance welding for hermetical seal.
- Tight tolerance 10 ppm available.
- Lead Free and RoHS compliant

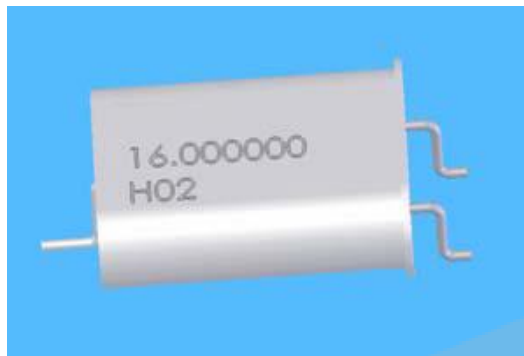

ORDERING GUIDANCE

Product Type	Oscillation Mode	Calibration Tolerance (ppm)	Temperature Stability (ppm)	Operation Temp Range (°C)	Load Capacitance (pF)	Frequency (MHz)
Code: Meaning	Code: Meaning	Code: Meaning	Code: Meaning	Code: Meaning	Code: Meaning	
U2:	1: Fund 3: 3 rd OT 5: 5 th OT	A: ±10 B: ±15 C: ±20 D: ±30 F: ±50 G: ±5 H: ±25 XX: Special	1: ±10 2: ±15 3: ±20 4: ±30 5: ±50 6: ±100 7: ±5 8: ±3 9: ±25 00: Special	A: -10~+60 B: 0~+70 C: -20~+70 D: -40~+85 E: -55~+125 F: -10~+70 G: -40~+60 H: 0~+60 I: -20~+60 J: -40~+105 K: -40~+70 L: -40~+125	0: Series XX: CL Value In pF	XXX.XXXXXX

Ordering example: U2-1C4B18-10.000000MHz
 HC-49/U Gull-wing Fund ±20ppm ±30ppm/0~+70°C 18pF 10.000000MHz

Note: If any other requirements are needed, they should be specified in customers' order.

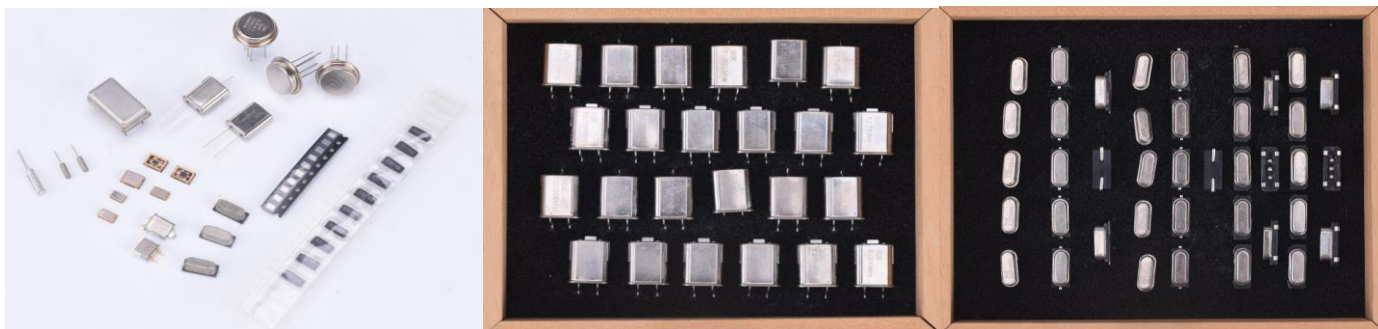

HANGZHOU FREQCONTROL ELECTRONIC TECHNOLOGY LTD.

Head office : # 1106, Crystal International Business Center(CIBC), No.198
 Wuxing Rd ,Qianjiang new city Hangzhou, P.R.China Post code: 310006
 TEL: 0086-571-85803723 85803731 85803732 FAX: 0086-571-85803724
 E-mail: sales@csimc-freqcontrol.com thwu@mail.hz.zj.cn





We are committed to the supply of all types of substrate wafers to the microelectronics industry

**Electrical Specification
Resistance(ESR)**

Storage Temp. Range	-55°C to +125°C
Drive Level(DL)	100uW typ., 500uW
Shunt Capacitance(C0)	7.0pF Max.
Insulation Resistance(IR)	500MΩ Min. @ 100V DC
Aging	±3ppm/year

Equivalent Series

Frequency (MHz)	Mode	Max ESR (Ohms)
1.800 – 1.999	Fund	750
2.000 – 2.399	Fund	500
2.400 – 3.199	Fund	300
3.200 – 4.199	Fund	100
4.200 – 4.899	Fund	70
4.900 – 5.999	Fund	50
6.000 – 9.999	Fund	40
10.000 – 15.999	Fund	30
16.000 – 35.000	Fund	20
20.000 – 24.999	3 rd O/T	60
25.000 – 100.000	3 rd O/T	40
60.000 – 79.999	5 th O/T	80
80.000 – 150.000	5 th O/T	60

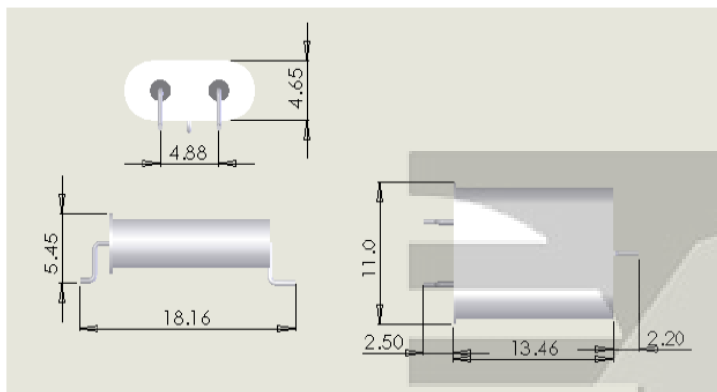

CHINA QUARTZ TECHNOLOGY

HANGZHOU FREQCONTROL ELECTRONIC TECHNOLOGY LTD.

Head office : # 1106, Crystal International Business Center(CIBC), No.198
 Wuxing Rd ,Qianjiang new city Hangzhou, P.R.China Post code: 310006
 TEL: 0086-571-85803723 85803731 85803732 FAX: 0086-571-85803724
 E-mail: sales@csimc-freqcontrol.com thwu@mail.hz.zj.cn

