



SAW Components

Data Sheet

CQTSR433M92.01

| | |
|---|-------|
| Customer's Approval Certificate | |
| Complies with Directive 2002/95/EC (RoHS) | |
| Please return this Page Via email as a certification of Your approval | |
| Checked & Approval by: | Date: |
| | |

Hangzhou Freq-control Electronics Technology Co.,Ltd.
TEL:0086-571-85803723
FAX:0086-571-85803724
sales@csimc-freqcontrol.com

1. Package Dimension

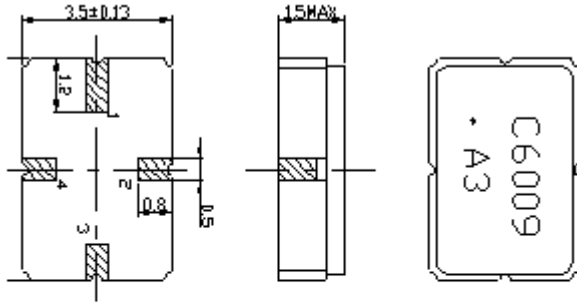

| Pin No. | Function |
|---------|-------------|
| 2 | Input |
| 4 | Output |
| 1,3 | Case Ground |

2. Marking

| | |
|-------|----------------|
| C6009 | (1) Model code |
| A3 | (2) Date code |

| | |
|------------|---------------------|
| A | 3 |
| Month code | Last figure of year |

| | | | | | | | | | | | | |
|------------|---|---|---|---|---|---|---|---|---|----|----|----|
| Month | 1 | 2 | 3 | 4 | 5 | 6 | 7 | 8 | 9 | 10 | 11 | 12 |
| Month code | A | B | C | D | E | F | G | H | I | J | K | L |

3. Performance

3.1 Application

One-port SAW Resonator for Wireless Remote Controller.

Center frequency: 433.92MHz

3.2 Maximum Rating

| Rating | | Value | Unit |
|------------------------------------|-----------|------------|------|
| Operating Temperature Range | T_A | -40 ~ +85 | °C |
| Storage Temperature Range | T_{stg} | -45 ~ +125 | °C |
| DC Voltage (between any Terminals) | V_{DC} | 10 | V |
| RF Power (in <i>BW</i>) | P | 10 | dBm |
| ESD Voltage (HB) | V_{ESD} | 150 | V |

3.3 Electronic Characteristics

| Item | Unit | Minimum | Typical | Maximum |
|-----------------------------------|---------------------|---------|---------|---------|
| Center Frequency (f_0) | MHz | 433.845 | 433.920 | 433.995 |
| Insertion Loss | dB | — | 1.2 | 2.0 |
| Quality Factor | — | — | — | — |
| Unloaded Q | — | — | 11,000 | — |
| 50Ω Loaded Q | — | — | 2,000 | — |
| Temperature Stability | — | — | — | — |
| Turnover Temperature | °C | 25 | 35 | 50 |
| Frequency Temperature Coefficient | ppm/°C ² | — | 0.032 | — |
| Frequency Aging | ppm/yr | — | <±10 | — |
| DC Insulation Resistance | MΩ | 1.0 | — | — |
| RF Equivalent RLC Model | — | — | — | — |
| Motional Resistance R_1 | Ω | — | 18 | 26 |
| Motional Inductance L_1 | μ H | — | 86 | — |
| Motional Capacitance C_1 | fF | — | 1.56 | — |
| Shunt Static Capacitance C_0 | pF | 1.7 | 2.0 | 2.3 |

3.4 Test Circuit

