



SAW Components

Data Sheet

CQTSR340M00.01

Customer' s Approval Certificate	
Complies with Directive 2002/95/EC (RoHS)	
Please return this Page Via email as a certification of Your approval	
Checked & Approval by:	Date:

Hangzhou Freq-control Electronics Technology Co.,Ltd.

TEL:0086-571-85803723

FAX:0086-571-85803724

sales@csimc-freqcontrol.com

1. Package Dimension

Unit: mm

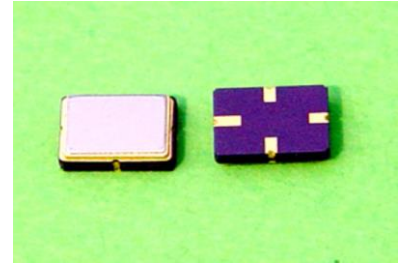
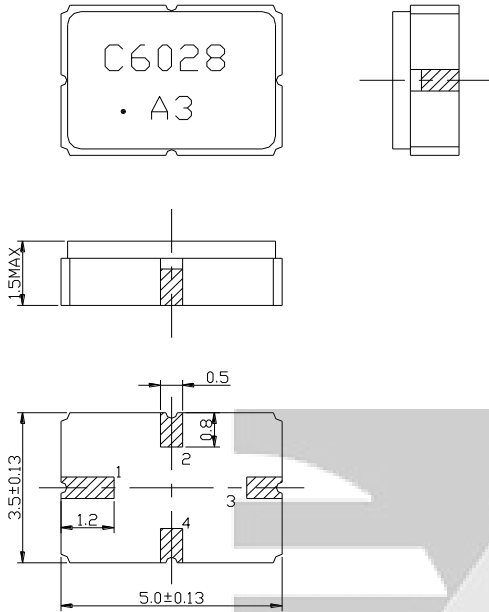

Pin No.	Function
2	Input
4	Output
1,3	Case Ground

2. Marking

C6028	(1) Model code
A3	(2) Date code

A	3
Month code	Last figure of year

Month	1	2	3	4	5	6	7	8	9	10	11	12
Month code	A	B	C	D	E	F	G	H	I	J	K	L

3. Performance

3.1 Application

One-port SAW Resonator for Wireless Remote Controller.

Center frequency: 340.0MHz

3.2 Maximum Rating

Rating		Value	Unit
Operating Temperature Range	T_A	-40 ~ +85	°C
Storage Temperature Range	T_{stg}	-45 ~ +125	°C
DC Voltage (between any Terminals)	V_{DC}	10	V
RF Power (in BW)	P	10	dBm
ESD Voltage (HB)	V_{ESD}	150	V

Electrostatic Sensitive Device (ESD)

3.3 Electronic Characteristics

Item	Unit	Minimum	Typical	Maximum
Center Frequency (f_0)	MHz	339.925	340.00	340.075
Insertion Loss	dB	—	1.35	2.0
Quality Factor	—	—	—	—
Unloaded Q	—	—	11,000	—
50Ω Loaded Q	—	—	2,000	—
Temperature Stability	—	—	—	—
Turnover Temperature	°C	—	39	—
Frequency Temperature Coefficient	ppm/°C ²	—	0.032	—
Frequency Aging	ppm/yr	—	<±10	—
DC Insulation Resistance	MΩ	1.0	—	—
RF Equivalent RLC Model	—	—	—	—
Motional Resistance R_1	Ω	—	14	21
Motional Inductance L_1	μH	—	63	—
Motional Capacitance C_1	fF	—	2.5	—
Shunt Static Capacitance C_0	pF	2.6	2.9	3.2

3.4 Test Circuit

