

# INTERNATIONAL STANDARD

---

**Synthetic quartz crystal – Specifications and guidelines for use**



## THIS PUBLICATION IS COPYRIGHT PROTECTED

Copyright © 2008 IEC, Geneva, Switzerland

All rights reserved. Unless otherwise specified, no part of this publication may be reproduced or utilized in any form or by any means, electronic or mechanical, including photocopying and microfilm, without permission in writing from either IEC or IEC's member National Committee in the country of the requester.

If you have any questions about IEC copyright or have an enquiry about obtaining additional rights to this publication, please contact the address below or your local IEC member National Committee for further information.

IEC Central Office  
3, rue de Varembe  
CH-1211 Geneva 20  
Switzerland  
Email: [inmail@iec.ch](mailto:inmail@iec.ch)  
Web: [www.iec.ch](http://www.iec.ch)

### About the IEC

The International Electrotechnical Commission (IEC) is the leading global organization that prepares and publishes International Standards for all electrical, electronic and related technologies.

### About IEC publications

The technical content of IEC publications is kept under constant review by the IEC. Please make sure that you have the latest edition, a corrigenda or an amendment might have been published.

- Catalogue of IEC publications: [www.iec.ch/searchpub](http://www.iec.ch/searchpub)

The IEC on-line Catalogue enables you to search by a variety of criteria (reference number, text, technical committee,...). It also gives information on projects, withdrawn and replaced publications.

- IEC Just Published: [www.iec.ch/online\\_news/justpub](http://www.iec.ch/online_news/justpub)

Stay up to date on all new IEC publications. Just Published details twice a month all new publications released. Available on-line and also by email.

- Electropedia: [www.electropedia.org](http://www.electropedia.org)

The world's leading online dictionary of electronic and electrical terms containing more than 20 000 terms and definitions in English and French, with equivalent terms in additional languages. Also known as the International Electrotechnical Vocabulary online.

- Customer Service Centre: [www.iec.ch/webstore/custserv](http://www.iec.ch/webstore/custserv)

If you wish to give us your feedback on this publication or need further assistance, please visit the Customer Service Centre FAQ or contact us:

Email: [csc@iec.ch](mailto:csc@iec.ch)  
Tel.: +41 22 919 02 11  
Fax: +41 22 919 03 00



IEC 60758

Edition 4.0 2008-11

# INTERNATIONAL STANDARD

---

**Synthetic quartz crystal – Specifications and guidelines for use**

INTERNATIONAL  
ELECTROTECHNICAL  
COMMISSION

PRICE CODE



---

ICS 31.140

ISBN 2-8318-1016-2

## CONTENTS

FOREWORD .....	5
1 Scope .....	7
2 Normative references .....	7
3 Terms and definitions .....	7
4 Specification for as-grown synthetic quartz crystal .....	11
4.1 Standard values .....	11
4.1.1 Orientation of the seed.....	11
4.1.2 Inclusion density .....	11
4.1.3 Infrared quality indications, $\alpha_{3500}$ , $\alpha_{3585}$ , $\alpha_{3410}$ .....	11
4.1.4 Frequency-versus-temperature characteristics (Figure 4 and 4.2.7).....	12
4.1.5 Etch channel density $\rho$ .....	12
4.2 Requirements and measuring methods.....	13
4.2.1 Orientation.....	13
4.2.2 Handedness .....	13
4.2.3 Synthetic quartz crystal dimensions .....	13
4.2.4 Seed dimensions .....	13
4.2.5 Imperfections .....	13
4.2.6 Evaluation of infrared quality by alpha-measurement .....	15
4.2.7 Frequency versus temperature characteristics.....	17
4.2.8 Etch channel density.....	18
4.3 Marking.....	19
4.3.1 Shipping requirements .....	19
5 Specification for lumbered synthetic quartz crystal .....	20
5.1 Standard values .....	20
5.1.1 Tolerance of dimensions .....	20
5.1.2 Reference surface flatness.....	20
5.1.3 Angular tolerance of reference surface .....	20
5.1.4 Centrality of the seed.....	20
5.2 Requirements and measuring methods.....	20
5.2.1 As-grown quartz bars used for lumbered quartz bars .....	20
5.2.2 Dimensions of lumbered synthetic quartz crystal .....	20
5.2.3 Identification on reference surface .....	20
5.2.4 Measurement of reference surface flatness.....	20
5.2.5 Measurement of reference surface angle tolerance.....	20
5.2.6 Centrality of the seed.....	20
5.3 Delivery conditions.....	21
5.3.1 Marking .....	21
5.3.2 Packing .....	21
5.3.3 Making batch .....	21
6 Inspection rule for synthetic quartz crystal and lumbered synthetic quartz crystal.....	21
6.1 Inspection rule for as-grown synthetic quartz crystal .....	21
6.1.1 Inspection.....	21
6.1.2 Lot-by-lot test.....	21
6.2 Inspection rule for lumbered synthetic quartz crystal .....	22
6.2.1 Lot-by-lot test.....	23
7 Guidelines for the use of synthetic quartz crystal .....	23

7.1	General	23
7.1.1	Overview	23
7.1.2	Synthetic quartz crystal	23
7.2	Shape and size of synthetic quartz crystal	24
7.2.1	Crystal axis and face designation	24
7.2.2	Seed	24
7.2.3	Shapes and dimensions	24
7.2.4	Growth zones	24
7.3	Standard method for evaluating the quality of synthetic quartz crystal	25
7.4	Other methods for checking the quality of synthetic quartz crystal	25
7.4.1	Visual inspection	25
7.4.2	Infrared radiation absorption method	26
7.4.3	Miscellaneous	26
7.5	Alpha-grade	27
7.6	Optional grading (only as ordered), in inclusions, etch channels, Al content	27
7.6.1	Inclusions	27
7.6.2	Etch channels	27
7.6.3	Al content	27
7.6.4	Swept quartz	28
7.7	Ordering	28
Annex A (informative)	Frequently used sampling procedures	38
Annex B (informative)	Numerical example	40
Annex C (informative)	Example of reference sample selection	41
Annex D (informative)	Explanations of point callipers	42
Annex E (informative)	Infrared absorbance alpha value compensation	43
Annex F (informative)	The differences of the orthogonal axial system for quartz between IEC standard and IEEE standard	47
	Bibliography	49
	Figure 1 – Idealized sections of a synthetic quartz crystal grown on a Z-cut seed	29
	Figure 2 – Quartz crystal axis and face designation	30
	Figure 3 – Typical example of cutting wafers of AT-cut plate, minor rhombohedral-cut plate, X-cut plate, Y-cut plate and Z-cut plate	31
	Figure 4 – Frequency-temperature characteristics of the test specimen for slope	32
	Figure 5 – Quartz crystal axis and face designation	33
	Figure 6 – A synthetic quartz crystal grown on a Z-cut seed of small X-dimensions	34
	Figure 7 – An example of an early 1970s relation between the extinction coefficient of infra-red radiation and the Q-value of synthetic quartz	34
	Figure 8 – Lumbered synthetic quartz crystal outline and dimensions along X-, Y- and Z-axes	35
	Figure 9 – Angular deviation for reference surface	36
	Figure 10 – Centrality of the seed with respect to the dimension along the Z- or Z'-axis	37
	Figure D.1a – Point callipers	42
	Figure D.1b – Digital point callipers	42
	Figure E.1 – Schematic of measurement set-up	44

Figure E.2 – Graph relationship between averaged alpha and measured alpha at three wave numbers of  $\alpha_{3500}$ ,  $\alpha_{3585}$  and  $\alpha_{3410}$  ..... 46

Figure F.1 – Left- and right-handed quartz crystals ..... 48

Table 1 – Inclusion densities for the grades ..... 11

Table 2 – Infrared quality indications for the grades ..... 12

Table 3 – Etch channel densities for the grades ..... 12

Table 4 – Test conditions and requirements for the lot-by-lot test for group A ..... 22

Table 5 – Test conditions and requirements for the lot-by-lot test for group B ..... 22

Table 6 – Test conditions and requirements for the lot-by-lot test ..... 23

Table B.1 – Commodity bar sampling, method 1 ..... 40

Table B.2 – Commodity bar sampling ..... 40

Table E.1 – Example of calibration data at  $\alpha_{3585}$  ..... 45

Table E.2 – Example of calibration data at  $\alpha_{3500}$  ..... 45

Table E.3 – Example of calibration data at  $\alpha_{3410}$  ..... 45

## INTERNATIONAL ELECTROTECHNICAL COMMISSION

---

**SYNTHETIC QUARTZ CRYSTAL –  
SPECIFICATIONS AND GUIDELINES FOR USE****FOREWORD**

- 1) The International Electrotechnical Commission (IEC) is a worldwide organization for standardization comprising all national electrotechnical committees (IEC National Committees). The object of IEC is to promote international co-operation on all questions concerning standardization in the electrical and electronic fields. To this end and in addition to other activities, IEC publishes International Standards, Technical Specifications, Technical Reports, Publicly Available Specifications (PAS) and Guides (hereafter referred to as "IEC Publication(s)"). Their preparation is entrusted to technical committees; any IEC National Committee interested in the subject dealt with may participate in this preparatory work. International, governmental and non-governmental organizations liaising with the IEC also participate in this preparation. IEC collaborates closely with the International Organization for Standardization (ISO) in accordance with conditions determined by agreement between the two organizations.
- 2) The formal decisions or agreements of IEC on technical matters express, as nearly as possible, an international consensus of opinion on the relevant subjects since each technical committee has representation from all interested IEC National Committees.
- 3) IEC Publications have the form of recommendations for international use and are accepted by IEC National Committees in that sense. While all reasonable efforts are made to ensure that the technical content of IEC Publications is accurate, IEC cannot be held responsible for the way in which they are used or for any misinterpretation by any end user.
- 4) In order to promote international uniformity, IEC National Committees undertake to apply IEC Publications transparently to the maximum extent possible in their national and regional publications. Any divergence between any IEC Publication and the corresponding national or regional publication shall be clearly indicated in the latter.
- 5) IEC provides no marking procedure to indicate its approval and cannot be rendered responsible for any equipment declared to be in conformity with an IEC Publication.
- 6) All users should ensure that they have the latest edition of this publication.
- 7) No liability shall attach to IEC or its directors, employees, servants or agents including individual experts and members of its technical committees and IEC National Committees for any personal injury, property damage or other damage of any nature whatsoever, whether direct or indirect, or for costs (including legal fees) and expenses arising out of the publication, use of, or reliance upon, this IEC Publication or any other IEC Publications.
- 8) Attention is drawn to the Normative references cited in this publication. Use of the referenced publications is indispensable for the correct application of this publication.
- 9) Attention is drawn to the possibility that some of the elements of this IEC Publication may be the subject of patent rights. IEC shall not be held responsible for identifying any or all such patent rights.

International Standard IEC 60758 has been prepared by IEC technical committee 49: Piezoelectric and dielectric devices for frequency control and selection.

This fourth edition cancels and replaces the third edition, published in 2004. This edition constitutes a technical revision.

This edition includes the following significant technical changes with respect to the previous edition:

- preparation of AT-cut slice sample for etching is changed to make it easier;
- etch channel grade classification is changed considering request of the user;
- explanation of quartz axes difference between IEEE and IEC is added as Annex F.

The text of this standard is based on the following documents:

FDIS	Report on voting
49/808/FDIS	49/814/RVD

Full information on the voting for the approval of this standard can be found in the report on voting indicated in the above table.

This publication has been drafted in accordance with the ISO/IEC Directives, Part 2.

The committee has decided that the contents of this publication will remain unchanged until the maintenance result date indicated on the IEC web site under "<http://webstore.iec.ch>" in the data related to the specific publication. At this date, the publication will be

- reconfirmed,
- withdrawn,
- replaced by a revised edition, or
- amended.

A bilingual version of this publication may be issued at a later date.



# SYNTHETIC QUARTZ CRYSTAL – SPECIFICATIONS AND GUIDELINES FOR USE

## 1 Scope

This International Standard applies to synthetic quartz single crystals intended for manufacturing piezoelectric elements for frequency control and selection.

## 2 Normative references

The following referenced documents are indispensable for the application of this document. For dated references, only the edition cited applies. For undated references, the latest edition of the referenced document (including any amendments) applies.

IEC 60068-1:1988, *Environmental testing – Part 1: General and guidance*  
Amendment 1: 1992

IEC 60122-1:2002, *Quartz crystal units of assessed quality – Part 1: Generic specification*

IEC 60410:1973, *Sampling plans and procedures for inspection by attributes*

IEC 61994 (all parts), *Piezoelectric and dielectric devices for frequency control and selection – Glossary*

## 3 Terms and definitions

For the purposes of this document, the following terms and definitions, as well as those given in IEC 61994, apply.

### 3.1

#### **hydrothermal crystal growth**

literally, crystal growth in the presence of water, elevated temperatures and pressures by a crystal growth process believed to proceed geologically within the earth's crust. The industrial synthetic quartz growth processes utilize alkaline water solutions confined within autoclaves at supercritical temperatures (330 °C to 400 °C) and pressures (700 to 2 000 atmospheres).

NOTE The autoclave is divided into two chambers: the dissolving chamber, containing raw quartz chips at the higher temperature; the growing chamber, containing cut seeds at the lower temperature (see 7.1.2)

### 3.2

#### **synthetic quartz crystal**

single crystal of  $\alpha$  quartz grown by the hydrothermal method. The crystal is of either handedness and in the as-grown condition. Cultured quartz has the same meaning as synthetic quartz crystal

#### 3.2.1

##### **as-grown synthetic quartz crystal**

single crystal quartz grown hydrothermally. As-grown refers to the state of processing and indicates a state prior to whatever treatment might occur after growth, excluding quality control operations

### 3.2.2

#### **as-grown Y-bar**

crystals which are produced using seed with the largest dimension in the Y-direction

### 3.2.3

#### **as-grown Z-bar**

crystals in which the Z-grown sector is much larger than the X-grown sector. The relative size of the growth sector is controlled by the X-dimension of the seed

### 3.3

#### **synthetic quartz crystal batch**

synthetic quartz crystals grown at the same time in one autoclave

### 3.4

#### **seed**

rectangular parallelepiped quartz plate or bar to be used as a nucleus for crystal growth

### 3.5

#### **growth zones**

regions of a synthetic quartz crystal resulting from growth along different crystallographic directions (see Figure 1)

### 3.6

#### **orientation of a synthetic quartz crystal**

orientation of its seed with respect to the orthogonal axes specified in 3.7

### 3.7

#### **orthogonal axial system of $\alpha$ quartz crystal**

orthogonal axis system consists of three axes with a mutually vertical X axis, Y axis, and Z axis

#### 3.7.1

##### **axial system for quartz (illustrated in Figure 2)**

NOTE The z-cut seed may be oriented at an angle of less than 20' to the Y-axis, in this case the axial system becomes x, Y', z'.

#### 3.7.2

##### **AT-cut plate**

rotated Y-cut crystal plate oriented at an angle of about +35° around the X-axis or about -3° from the z (minor rhombohedral)-face as shown in Figure 3

#### 3.7.3

##### **z (minor rhombohedral)-cut plate**

crystal plate parallel to the z (minor rhombohedral)-face as shown in Figure 3a

#### 3.7.4

##### **X-cut plate**

crystal plate perpendicular to the X-axis as shown in Figure 3b

#### 3.7.5

##### **Y-cut plate**

crystal plate perpendicular to the Y-axis as shown in Figure 3b

#### 3.7.6

##### **Z-cut plate**

crystal plate perpendicular to the Z-axis as shown in Figure 3b

### **3.8 dimensions**

dimensions pertaining to growth on Z-cut seed rotated less than 20° from the Y-axis

#### **3.8.1 gross dimensions**

maximum dimensions along the X-, Y-, or Y' and Z or Z' axes measured along the X-, Y'- and Z'-axes

##### **3.8.1.1 effective Z-dimension**

as-grown effective Z dimension defined as the minimum measure in the Z ( $\theta=0^\circ$ ) or Z' direction in usable Y or Y' area of an as-grown crystal and described by  $Z_{\text{eff}}$ , as shown in Figure 1

##### **3.8.1.2 minimum Z-dimension**

minimum distance from seed surface to Z-surface described by  $Z_{\text{min}}$  as shown in Figure 1d

#### **3.8.2 dimensions pertaining to growth on a Z-cut seed rotated more than 20° from the X-axis** (under consideration)

### **3.9 inclusions**

any foreign material within a synthetic quartz crystal, visible by examination of scattered light from a bright source with the crystal immersed in a refractive index-matching liquid.

A particularly common inclusion is the mineral acmite (sodium iron silicate)

#### **3.9.1 seed veil**

array of inclusions or voids at the surface of the seed upon which a crystal has been grown

#### **3.9.2 etch channel**

roughly cylindrical void that is present along the dislocation line after etching a quartz crystal

### **3.10 do pant**

any additive used in the growth process which may change the crystal habit, chemical composition, physical or electrical properties of the synthetic quartz batch

### **3.11 pre-dimensioned bar**

any bar whose as-grown dimensions have been altered by sawing, grinding, lapping, etc., to meet a particular dimensional requirement

### **3.12 impurity concentration**

concentration of impurities relative to silicon atoms

### 3.13

#### **dislocations**

linear defects in the crystal due to misplaced planes of atoms

### 3.14

#### **etch channel**

roughly cylindrical void present along a dislocation line after etching a test wafer prepared from a quartz crystal

### 3.15

#### **autoclave**

vessel for the high-pressure high-temperature condition required for growth of a synthetic quartz crystal

### 3.16

#### **right-handed quartz or left-handed quartz**

handedness of quartz crystal as determined by observing the sense of handedness of the optical rotation in the polarized light. Right-handed quartz is the crystal of dextrorotatory and left-handed quartz is the crystal of levorotary

### 3.17

#### **twins**

follow laws of crystallography relating symmetrically to specific faces or axes.

The following types have been identified in synthetic quartz crystals:

a) **Electrical twins**

Quartz crystal in which regions with the common Z-axis exist showing a polarity reversal of the electrical X-axis.

b) **Optical twins**

Quartz crystal in which regions with the common Z-axis exhibit handedness reversal of the optical Z-axis

### 3.18

#### **infrared absorption coefficient $\alpha$ -value**

coefficient (referred to as the  $\alpha$ -value) established by determining the relationship between absorption of two wavelengths: one with minimal absorption due to OH impurity, the other with high absorption due to presence of OH impurities in the crystal lattice. The OH impurity creates mechanical loss in resonators and its presence is correlated to the presence of other loss-inducing impurities. The  $\alpha$ -value is a measure of OH concentration and is correlated with expected mechanical losses due to material impurities. The infrared absorption coefficient  $\alpha$ -value is determined using the following equation:

$$\alpha = \frac{1}{t} \log \frac{T_1}{T_2}$$

where

$\alpha$  is the infrared absorption coefficient;

$t$  is the thickness of Y-cut sample, in cm ;

$T_1$  is the per cent transmission at a wave number of 3 800 cm<sup>-1</sup> or 3 979 cm<sup>-1</sup>;

$T_2$  is the per cent transmission at a wave number of 3 410 cm<sup>-1</sup>, 3 500 cm<sup>-1</sup>, or 3 585 cm<sup>-1</sup>.

**3.19****lumbered synthetic quartz crystal**

synthetic quartz crystal whose X- and Z- or Z'- surfaces in the as-grown condition have been processed flat and parallel by sawing, grinding, lapping, etc., to meet specified dimensions and orientation

**3.19.1****lumbered Y-bar**

quartz bars which are lumbered from an as-grown Y-bar

**3.19.2****lumbered Z-bar**

quartz bars which are lumbered from an as-grown Z-bar

**3.20****reference surface**

surface of the lumbered bar prepared to specific flatness and orientation with respect to a crystallographic direction (typically the X-direction)

**4 Specification for as-grown synthetic quartz crystal****4.1 Standard values****4.1.1 Orientation of the seed**

Standard orientation for the seeds are Z-cuts and rotated X-cuts, minor rhombohedral (z-minor) cut, 1° 30' rotated Z-cut, 2° rotated Z-cut, 5° rotated Z-cut, and 8° 30' rotated Z-cut, the Z'-axis of the latter three seeds being rotated as shown in Figure 2.

**4.1.2 Inclusion density**

The inclusion density (measured as in 4.2.5.3) for each grade shall not exceed the figures in any required size range for that grade listed in Table 1 .

**Table 1 – Inclusion densities for the grades**

Grade/size Range  μm	Densities per cm <sup>3</sup>			
	10-30	30-70	70-100	>100
I a	2	1	0	0
I b	3	2	1	1
I	6	4	2	2
II	9	5	4	3
III	12	8	6	4

Users requiring a grade in only one or more of the size ranges may designate their requirement as the grade followed by the appropriate size range.

**4.1.3 Infrared quality indications,  $\alpha_{3500}$ ,  $\alpha_{3585}$ ,  $\alpha_{3410}$** 

An infrared extinction coefficient value ( $\alpha$ -value) of synthetic quartz (measured as in 4.2.6) shall be as listed under the appropriate heading for  $\alpha_{3500}$ ,  $\alpha_{3585}$ , or  $\alpha_{3410}$  in Table 2 for the various grades:

**Table 2 – Infrared quality indications for the grades**

Grades	Maxima			Pre-1987 <sup>a</sup>
	$\alpha_{3\ 500}$	$\alpha_{3\ 585}$	$\alpha_{3\ 410}$	Q · 10 <sup>6</sup> units
Aa	0,026	0,015	0,075	3,8
A	0,033	0,024	0,082	3,0
B	0,045	0,050	0,100	2,4
C	0,060	0,069	0,114	1,8
D	0,080	0,100	0,145	1,4
E	0,120	0,160	0,190	1,0

a These Q-values were obtained from  $\alpha$ -measurements and empirical correlation, and were in common usage prior to 1987. These are included here as the previous labels to maintain continuity through the change in emphasizing  $\alpha$ -labels.  $\alpha$  is the physical measurement now used to control and specify quality in synthetic quartz.

The test limits above either correspond to or are unchanged (except in the cases of grades B and D) from the  $\alpha_{3500}$  limits that correspond to the Q-value grades listed in the first edition of IEC 60758. This earlier publication designated some of the same grades in terms of minimum indicated Q's in 106 units, as follows:

- A = 3,0;
- B = 2,2 (basis used herein), changed from 2,4 in the earlier edition;
- C = 1,8;
- D = 1,4 (revised);
- E = 1,0 (the same as the earlier D-grade).

**4.1.4 Frequency-versus-temperature characteristics (Figure 4 and 4.2.7)**

The frequency-versus-temperature characteristics of synthetic quartz crystal units shall be assessed by determination of the fractional frequency deviation measured at 15 °C and 35 °C with respect to the series resonance frequency at 25 °C. The fractional deviation shall satisfy the following:

- fractional frequency deviation at 15 °C: +0,5 to +1,5 × 10<sup>-6</sup>;
- fractional frequency deviation at 35 °C: -0,5 to -1,5 × 10<sup>-6</sup>.

Measurement shall be made in accordance with 4.7.3 of IEC 60122-1 .

**4.1.5 Etch channel density  $\rho$**

When required, the etch channel density,  $\rho$ , per cm<sup>2</sup> (measured as in 4.2.8) for each grade, shall comply with the listings in Table 3.

**Table 3 – Etch channel densities for the grades**

Grade	Maximum number $\rho$ per cm <sup>2</sup>
1aa	2
1a	5
1	10
2	30
3	100
4	300

## 4.2 Requirements and measuring methods

### 4.2.1 Orientation

The orientation of the seed shall be along specified directions, with a deviation of less than 30 min from nominal.

### 4.2.2 Handedness

The handedness of the seed shall be specified, either right-hand or left-hand (see Figure 2).

### 4.2.3 Synthetic quartz crystal dimensions

The dimension shall be measured by callipers or point callipers which enable the hollow point of a synthetic quartz crystal to be measured (see Annex D).

#### 4.2.3.1 Dimension along Y or Y'- axis

The dimension shall be as specified (see Figure 1d).

#### 4.2.3.2 Dimension along Z or Z'-axis dimension shall be measured by a neck callipers

The dimension along the Z or Z'-axis shall be specified as the maximum dimension along the Z or Z'-axis in the greater X zone (see Figure 1c).

#### 4.2.3.3 Dimension $Z_{\text{eff}}$ or $Z'_{\text{eff}}$

The  $Z_{\text{eff}}$  or  $Z'_{\text{eff}}$  dimension shall be specified as the minimum dimension along the Z or Z'-axis (see Figure 1c).

#### 4.2.3.4 Dimension $Z_{\text{min}}$ or $Z'_{\text{min}}$

The dimension shall be as specified (see Figures 1c and 1d).

#### 4.2.3.5 Dimension along X-axis

The gross dimension along the X-axis shall be as specified (see Figure 1c).

### 4.2.4 Seed dimensions

#### 4.2.4.1 Z or Z' dimension

The Z or Z'-dimension (i.e. thickness) of the Z-cut or rotated Z-cut seed shall be less than 3 mm, unless otherwise specified.

#### 4.2.4.2 X-dimension

The dimension X of the seed shall be as specified.

### 4.2.5 Imperfections

#### 4.2.5.1 Twinning

There shall be no electrical or optical twinning in the usable region. The existence of twinning shall be checked by visual inspection.

#### 4.2.5.2 Cracks and fractures

There shall be no cracks or fractures in the usable region. The existence of cracks and fractures shall be checked by visual inspection.

#### 4.2.5.3 Inclusion density

The following two measuring methods are used and either one may be chosen.

##### Method 1

Inclusions within stated ranges are counted visually per  $\text{cm}^3$  in sample volumes within a crystal using a stereo binocular microscope operating at  $30\times$  to  $40\times$  magnification equipped for counting within either a circular or a square field and with a calibrated reticule scale for determining particle sizes, intense side illumination (such as halogen lamps) over a recessed black matt background, an index matching liquid ( $n = 1,55$ , approximately) for transparency, and means of measuring the dimensions of the sample volumes counted.

##### Method 2

In case it is difficult to apply method 1, crystals are compared with reference samples appropriately representing each grade range, immersing within an index matching liquid ( $n = 1,55$  approximately) for transparency, or applying such liquid to the surface. The reference samples shall be agreed upon between the supplier and the user. An example for the reference sample selection procedure is given in Annex C.

#### 4.2.5.3.1 Sampling

Because of the considerable costs in time, labour and money, some plan for sampling both bars and regions within the bars is normally used by agreement between the supplier and the buyer when quality control of either inclusion density or etch channel density is required.

Clearly, the preferable low-cost inspection situation is the one in which the densities of inclusions or etch channels are well below the test limits, and infrequent samples can be justified. Since such situations are not always attainable, more rigorous inspection strategies will sometimes be required for appropriate density control, and shall be found, worked out, and agreed upon between the supplier and the user.

Sound statistical methods are required in order to meet appropriate agreed-upon assured quality level tests and ensure that the crystals and the volumes counted within them are sufficiently representative. Since sampling procedures and statistical confidence tests are described in the literature, their principles will not be repeated here.

#### 4.2.5.3.2 Batch sampling

In most batch sampling, a suitable sample bar or group of bars is chosen to represent the batch population. The number of bars shall depend on the number in the batch, the type of crystal, the intended application, the separation between the mean and the target inclusion densities and the AQL confidence level requirement needed to provide sufficient assurance that the batch inclusion density in each size range shall be below their applicable grade test limits. The sample bar group shall reasonably represent the batch with respect to inclusion densities. Deviations, if any, are allowed and shall be towards higher, not lower, inclusion densities for safe assurance.



#### 4.2.5.3.3 Volumes within a bar

A group of volumes within each sample bar is next chosen for inclusion counting. The boundaries of the volumes are defined by the area of the focal field of the microscope (or the outline of a square reticule) and either the height of the bar or the length range of the depth adjustment of the microscope chosen for use. It is necessary to determine and total the volumes throughout which counts are accumulated. The volumes selected for counting should include mainly regions (usually Z-growth zones as in Figure 3) whose material will be present and active in the finished devices and should not avoid dense inclusion volumes within these regions. The number of volumes per bar shall be at least six or more for reasonable statistical confidence.

The sample volume locations within a bar shall be appropriately distributed in its X-, Y-, Z-axes to include the variations of the inclusion density with these independent variables. Typical synthetic quartz bars (Figure 3a) are long in the Y- and small in the X- and Z-axes dimensions. Normally, the greatest variation of inclusion density appears over a zone's grown direction, for example the Z-dimension in the Z-zone (Figures 1a and 3). Thus, for large Z-crystals, the sampled regions shall be located at varied Z-distances from the seed to ensure that the bar's range of Z is well-represented by the group of sample volumes. Similarly, any noted variations over Y or X shall be sampled, if such variations are present.

To aid in distributing sample volumes within a typical bar, its lesser X-surface is marked with transverse Z'-lines, perpendicular to the seed at regular 10 mm intervals over the Y-length of the surface. Sample volumes for inclusion counting are chosen as needed from within each rectangle formed by the marks and the crystal surfaces. To locate the sample volumes at varied distances from the seed, in small crystals (where a Z-zone measures less than double the field diameter of the microscope), they should be alternated near and far from the seed. For larger crystals, the volumes should be sequenced in Z over its range to ensure that each inclusion band is represented in the sample volumes. Several frequently used sampling plans are illustrated in Annex A.

#### 4.2.5.3.4 Inclusion counting

The circular or square field of view chosen for counting within its marked rectangle is scanned vertically over its chosen X-height within the microscope's range of depth adjustment, as follows.

If the sample is a Y-bar with a relatively small X-height, the scans will be at a series of sites varied in Z along its length (under side illumination, with its lesser X-surface up). Beginning in a rectangle positioned at one end of the usable zone, an inclusion count is taken in an X-cylinder (or parallelepiped) volume. Starting slightly below the lesser X-surface (and not counting surface material), all visible inclusions in focus are categorized and counted in each of the size categories required by the customer's order: 10  $\mu\text{m}$  to 30  $\mu\text{m}$ , 30  $\mu\text{m}$  to 70  $\mu\text{m}$ , 70  $\mu\text{m}$  to 100  $\mu\text{m}$ , and greater than 100  $\mu\text{m}$ . The microscope is then lowered and the newly focused inclusions counted and added into their size categories. This process is continued through the chosen X-height; the procedure is repeated at the next sample position, and so on.

The counts from the bar's sample sites in each of the four size categories are summed by category and divided by the calculated total of the sampled volumes, to obtain an average count per  $\text{cm}^3$  for each category in one bar. The count averages in each category from all the sample bars from a run are averaged and recorded as required to represent the size distribution for the run. Maximum and minimum bar averages may also be recorded, if desired or required. A numerical example is given in Annex B.

#### 4.2.6 Evaluation of infrared quality by alpha-measurement

The infrared absorption per centimetre at one or more of 3 410, 3 500 or 3 585 wave numbers is measured in a Y-cut slice scan as the difference between the absorption at

the chosen wave number and absorption in the background outside the band, at  $3\,800\text{ cm}^{-1}$  or at  $3\,979\text{ cm}^{-1}$  when using a single beam instrument. Since  $\alpha$  are known to vary directly with the total Z-growth size distribution of the crystals in one batch, a user may designate his preference in the batch distribution for sample testing. Such choices are often either an average Z-crystal or a maximum Z-crystal (for worst-case maximum alpha-measurement).

The following two measuring methods are used and either one shall be chosen.

#### **Method 1**

The wave number is fixed and the positional transmission data are measured by scanning the sample.

#### **Method 2**

The sample is fixed and the transmission data are measured at chosen wave numbers on several points in the sample.

##### **4.2.6.1 Preparation of the Y cut slice**

The synthetic quartz crystal to be sampled is mounted on a substrate then sliced with a quartz saw to yield at least one Y-cut slice whose thickness after lapping and polishing will fall in the range of 5 mm to 10 mm. The 5 mm thickness is appropriate for high  $\alpha$  -material, to resolve its  $\alpha$  -variations; the mid-range for medium  $\alpha$ ; and the 10 mm thickness is appropriate for the lowest  $\alpha$  -material to measure its small absorption.

After sawing, the slice is lapped on both major surfaces: first, with a homogenized mixture of 25  $\mu\text{m}$  abrasive; second, with a homogenized mixture of 3  $\mu\text{m}$  abrasive. Further lapping to polish is optional and is preferred for low  $\alpha$ .

##### **4.2.6.2 Calibration of a standard Y-cut slice in an infrared spectrophotometer**

The infra-red spectrophotometer is turned on, allowed to warm and fully stabilize, then calibrated. The normal daily calibration includes its transmission (0 % - 100 %) or absorbance ( $\log T = 1,0 - 0$ ) limit settings, chart speed and synchronized sample scanning arrangement. For evaluation and normal use, a 1,5 mm width aperture is located in the sample beam. For the lowest  $\alpha$ -value measurements, a 5 mm width aperture may be required. The aperture's height shall not exceed the X-dimension of the seed or 5,0 mm. A polished Y-cut standard reference slice is placed first in the sample holder, which is then mounted in the scanning device.

The wave number control is set at a background setting (outside, but near the OH absorption band), usually  $3\,800 \pm 3\text{ cm}^{-1}$ , and the sample is translated through the beam with synchronized chart advance at the fixed wave number. Such scanning is done only in the Z-growth zones of the Y-cut slice (illustrated in Figures 1 and 3). In certain cases where background noise may be a problem, such as single beam operation, a higher background wave number  $3\,979 \pm 3\text{ cm}^{-1}$  may be used for lowered background noise. If the background scan trace is not reasonably flat outside the original seed's boundaries, a thin film of fluorolube grease shall be applied to both major surfaces of the semi-polished Y-cut slice. Baseline changes shall not exceed 0,02 absorption units during a background scan. After the sample has completed a successful scan at background, the wave number is adjusted to the chosen  $3\,410$ ,  $3\,500$  or  $3\,585 \pm 3\text{ cm}^{-1}$ . The sample is returned to its original position and the chart paper rerolled to the position where its wave number scan began. The sample is then scanned to plot its infra-red absorption at this wave number in the absorption band.

The calibration  $\alpha$ -values (maximum and minimum) are calculated from this reference scan, using the equation:

$$\alpha = \frac{A^{**} - A^{*}}{\text{Y-cut slice thickness in centimetres}}$$

where

$A^{*}$  is the chosen value of 3 800 and 3 979;

$A^{**}$  is the chosen value of 3 410 3 500 and 3 585

NOTE  $A$  is the logarithm (base 10) of the traction of the incident beam absorbed by the sample at the subscript wave number.

The spectrophotometer is considered in proper calibration if its  $\alpha_{\max}$  and  $\alpha_{\min}$  readings are repeatable within  $\pm 0,004$  units of the standard's values for them. A standardization correction may be calculated as needed to bring the instrument's reading on a standard slice to an accepted value and used while current.

#### 4.2.6.3 Test measurement of a Y-cut slice

After successful calibration, each prepared (preferably polished) unknown slice is scanned at the background and chosen OH absorption band wave numbers, using a thin film of oil as needed in cases where there is only a semi-polish. Their pertinent  $\alpha$ -values are calculated using the equation above. Regions excluded from this determination are  $\pm 2,0$  mm from the seed centre and the excess growth beyond the appropriate pre-dimensioned bar dimensions.

#### 4.2.6.4 Compensation of alpha value by standard sample

Correlation between the test equipment of each manufacturer cannot be assured by strict adherence to uniform measuring conditions and procedures. Therefore, it is necessary to establish a compensation value for  $\alpha$ . The recommended compensation value is determined by each manufacturer referencing the procedure described in Annex E.

#### 4.2.7 Frequency versus temperature characteristics

The specifications for the quartz crystal unit for evaluating the frequency-versus-temperature characteristics shall be as follows, and measurements shall be made as specified in IEC 60122-1 :

- frequency 10 MHz  $\pm$ 10 kHz (fundamental);
- location of specimen Z-zone;
- orientation of plate AT cut  $35^{\circ} 15' \pm 30''$ ;
- shape of plate square flat and parallel plate with one edge along the X-axis;
- lateral dimensions of plate 8 mm  $\times$  8 mm;
- diameter of electrodes  $4 \pm 0,1$  mm;
- plate back of frequency deviation 70  $+20/-0$  kHz;
- electrode material silver or gold;
- supporting points at two points on opposite corners;
- finish of surface lapped (average particle size of abrasive shall be less than 3  $\mu\text{m}$ ), then etched by 200 kHz;
- flatness of surface when illuminated with monochromatic light through an optical flat glass and examined within

a circular zone of 6 mm diameter, the product of the fringe curvature and the frequency expressed in MHz shall not exceed 5 if measured with yellow light or 6 if measured with green light;

- parallelism both surfaces of the plate shall be parallel within 10";
- seal hermetically enclosed in a dry nitrogen atmosphere at standard atmospheric conditions for temperature and pressure (see 5.1 of IEC 60068-1:1988).

The specification shall state minimum and maximum slope of frequency-versus-temperature characteristics (Figure 4).

#### 4.2.8 Etch channel density

The etch channel density is measured by counting channels in an etched AT-cut sample slice of the sampled quartz crystal as seen under a binocular microscope at up to 35x magnification.

##### 4.2.8.1 Sampling the crystals from a batch

Sampling a batch to achieve a specified statistical confidence level requires the use of AQL confidence statistics appropriate in this, the etch channel case, because the etch channel population depends on both the channels in the seeds and the process that grows the material on the seeds. It is preferable to pre-sort and group seeds for their etch channel densities and record their group locations in autoclaves or ensure that there is an adequate sample of the seeds as well as the growth on them, because of the possibility that some of the seeds may differ greatly from the others, unless intentionally controlled during planting.

##### 4.2.8.2 Preparation of AT cut slice for etching

A sample synthetic quartz crystal is cut to yield an AT-cut slice (at  $35,25^\circ \pm 3^\circ$  to the Y-plane) of a thickness to finish at **10 mm**. The slice should preferably contain full seed height, although thinner slices and lesser seed heights may be used in special cases, provided the specified amount of material is removed in each lapping. The slice's identity should be marked with a diamond scribe, preferably on its lesser X-surface, to an adequate depth to ensure that the identity will not be lost in lapping and etching.

After sawing and marking, the slice is lapped on both major surfaces; first, with a homogenized mixture of 25  $\mu\text{m}$  abrasive; second, on a cleaned lap with a homogenized mixture of 11,5  $\mu\text{m}$  abrasive. A minimum of 0,25 mm total thickness of quartz shall be removed in the first abrasive lapping, and of 0,10 mm total thickness in the second abrasive lapping. The slice is then cleaned to ensure a uniform etching rate over its surfaces, as evidenced by its uniform matt appearance after etching.

##### 4.2.8.3 Etching procedure for lapped AT-cut slice

Within a fume hood, using appropriate safety equipment (including apron, gloves, eyeglasses, and splatter shields), an excess of ammonium bifluoride is added to deionized water in a suitable container to make a saturated solution at  $75^\circ\text{C} \pm 2^\circ\text{C}$ . The ammonium bifluoride is maintained at the  $75^\circ\text{C} \pm 2^\circ\text{C}$  temperature, with the use of a constant temperature liquid bath. A polytetrafluoroethylene (PTFE)-coated thermometer in the solution is used for monitoring the temperature. If different etch temperatures are preferred, the etch time will be adjusted appropriately to comply with the stock removal requirement below.

The lapped and cleaned AT-cut slice is immersed into the saturated ammonium bifluoride solution using PTFE-coated tongs or an inert etching slice holder. The solution should be agitated or the sample slowly moved (approximately 25 mm per second) during the etching process. An etching time of about 4 h should be sufficient, depending on the agitation and the number of slices, to remove not less than 0,10 mm (minimum) or more than 0,12 mm (maximum) total thickness. Uniform etch rate is a requirement. The quartz slice shall be checked periodically for etch uniformity both in time and over the area of the slice. After etching is completed, the slice is removed from the etch solution with the PTFE-coated tongs, rinsed with hot water (85 °), then cleaned with acetone and other cleaning agents, if needed, to prepare the sample for unobstructed visual inspection.

#### 4.2.8.4 Etch channel counting procedure

A square grid of known dimensions in the range of 0,25 cm × 0,25 cm to 0,50 cm × 0,50 cm is marked on the AT-cut slice within the Z-growth zone as identified in Figure 3a. If preferred, the grid pattern may be drawn only over the rectangular portions of the Z-zones matching the height of the seed. No grid squares should be counted that fall within ±2 mm of the centre line of the seed.

Each slice is viewed with a binocular microscope using 30x to 40x magnification, and a strong light source directed into the slice in its lesser X-direction. Care shall be taken to focus the microscope on the upper surface of the sample, thus avoiding counting the etch channel intersections with the lower sample surface. The etch channels are counted and recorded in each and every square area with the microscope's zoom adjustment set for a convenient viewing magnification. After all the grid areas intended for counting are counted, their average count is calculated, and converted to an average per cm<sup>2</sup>,  $\rho$ , by multiplying by 16 for 0,25 cm × 0,25 cm, or 4 for 0,50 cm × 0,50 cm, etc., the number of grid squares in 1 cm<sup>2</sup>.

### 4.3 Marking

Each synthetic quartz crystal shall have the following information clearly marked on a major or lesser X-surface:

- a) manufacturer's name or trade mark;
- b) orientation of material;
- c) handedness of material:  
RH stands for right-handed quartz;  
LH stands for left-handed quartz;
- d) other information, if specified, to be marked such as:
  - 1) batch identification;
  - 2)  $\alpha$ -grade: Aa, A, B, C, D or E;
  - 3) inclusion density: Ia, Ib, I, II or III ;
  - 4) etch channel density: 1aa,1a,1, 2, 3 or 4.

#### 4.3.1 Shipping requirements

These requirements shall be specified upon agreement between the supplier and the user.

## **5 Specification for lumbered synthetic quartz crystal**

### **5.1 Standard values**

#### **5.1.1 Tolerance of dimensions**

Deviations from the specified dimensions along the X- and Z- or Z'- axes shall be less than 0,2 mm (see Figure 8).

#### **5.1.2 Reference surface flatness**

Reference surface shall be flat to within 0,2 mm or as specified. Care should be exercised in the selection of the method of measurement to isolate measures of reference surface deviations from those of the opposite side (parallelism).

#### **5.1.3 Angular tolerance of reference surface**

Angular deviations of the reference surface shall be less than 15' from the specified crystallographic direction (see Figure 9).

#### **5.1.4 Centrality of the seed**

Seed position in lumbered synthetic quartz crystal is shown in Figure 10.

### **5.2 Requirements and measuring methods**

#### **5.2.1 As-grown quartz bars used for lumbered quartz bars**

Raw materials for lumbered synthetic quartz crystal shall be in accordance with the standard values, related requirements and measuring methods of Clause 4 of this standard.

#### **5.2.2 Dimensions of lumbered synthetic quartz crystal**

Dimensions and tolerances shall be determined using callipers or micrometers by measuring at least at 3 points, one at the approximate midpoint of the Y-axis, and others symmetrically distributed along the Y-axis.

#### **5.2.3 Identification on reference surface**

Identification shall be marked on the reference surface and its presence confirmed by visual inspection. The content of the identification mark and the method of marking shall be determined by agreement between the supplier and the customer.

#### **5.2.4 Measurement of reference surface flatness**

A flatness of reference surface shall be measured by flatness measuring equipment as agreed between supplier and customer.

#### **5.2.5 Measurement of reference surface angle tolerance**

The deviation of the reference surface angle shall be measured by X-ray angle-measuring equipment.

#### **5.2.6 Centrality of the seed**

The centrality of the seed is determined by measuring the distance between lumbered surfaces and the nearest seed edge. An index matching liquid may be applied to the X surface to facilitate the measurement.

### **5.3 Delivery conditions**

The delivery conditions are to be implemented by agreement between the manufacturer and the user.

#### **5.3.1 Marking**

In the marking code of lumbered synthetic quartz crystals, the crystal growth batch number shall be stated.

#### **5.3.2 Packing**

Quartz crystal users shall receive in a single package a quantity of lumbered synthetic quartz crystals having similar dimensions along the X- and Z- or Z'-axes and made from crystals of a single batch.

#### **5.3.3 Making batch**

It is recommended that, when users are supplied with lumbered synthetic quartz crystals in large quantities, they shall be made from quartz crystals of a single batch.

## **6 Inspection rule for synthetic quartz crystal and lumbered synthetic quartz crystal**

### **6.1 Inspection rule for as-grown synthetic quartz crystal**

#### **6.1.1 Inspection**

The inspection of synthetic quartz crystal comprises lot-by-lot tests.

#### **6.1.2 Lot-by-lot test**

The lot-by-lot test consists of group A and group B inspection.

##### **6.1.2.1 Group A inspection**

The test schedule for group A inspection is given in Table 4 .

The statistical sampling and the inspection shall be in accordance with IEC 60410 or as otherwise agreed between buyer and seller.

The samples used for tests in group A may be used as the samples for group B tests.

**Table 4 – Test conditions and requirements for the lot-by-lot test for group A**

Test	D or ND	Test condition	IL	AQL %	Performance requirements
Minimum and maximum specified synthetic quartz crystal dimensions	ND	4.2.3	II	0,1	4.2.3.1
Twinning		4.2.5.1			4.2.5.1
Cracks and fractures		4.2.5.2			4.2.5.2
Inclusions	ND		II	0,4	4.1.2
<p>NOTE Subclause numbers of test conditions and performance requirements refer to Clause 4 of this standard.</p> <p>D : destructive                      ND : non-destructive                      IL : inspection level                      AQL: = acceptable quality level</p>					

**6.1.2.2 Group B inspection**

The test schedule for group B is given in Table 5 or as otherwise agreed between the buyer and the seller.

The samples for group B may be selected from the samples tested in group A.

**Table 5 – Test conditions and requirements for the lot-by-lot test for group B**

Test	D or ND	Test condition	Sample size criterion of acceptability		Performance requirements
			N	C	
Evaluation of infrared quality by $\alpha$ -measurement	D	4.2.6	One or more as agreed between buyer and seller provided one sample represents the large size group intended for application	0	4.1.3
Etch channel density	D		One or more as agreed between buyer and seller	0	4.1.5
<p>NOTE Subclause numbers of test conditions and performance requirements refer to Clause 4 of this standard.</p> <p>N: sample size (Z-bar or Y-bar)                      C: acceptance criterion (permitted number of defectives)                      D : destructive                      ND : non-destructive</p>					

Etch channel and  $\alpha$ -measurement may be performed on the same samples.

**6.2 Inspection rule for lumbered synthetic quartz crystal**

The inspection of lumbered synthetic quartz crystal comprises lot-by-lot tests.



## 6.2.1 Lot-by-lot test

### 6.2.1.1 Inspection lot

An inspection lot shall consist of all the lumbered synthetic quartz crystals produced and offered for inspection at one time.

Raw material for lumbered synthetic quartz crystal shall be in accordance with the standard values, related requirements and measuring methods of this standard.

### 6.2.1.2 Inspection requirements

The schedule for the lot-by-lot test is given in Table 6.

The statistical sampling and inspection shall be in accordance with IEC 60410 or as otherwise agreed between the buyer and the seller.

**Table 6 – Test conditions and requirements for the lot-by-lot test**

Test	D or ND	Test condition	IL	AQL %	Performance requirements
Dimensions and tolerances	ND	5.2.2	II	0,4	5.1.1
Reference surface flatness		5.2.4			5.1.2
Angular tolerance of reference surface		5.2.5			5.1.3
Centrality of the seed		5.2.6			5.1.4
Verification of reference surface identification		5.2.3			II
NOTE Subclause numbers of test conditions and performance requirements refer to Clause 5 of this standard.					
D	destructive				
ND	non-destructive				
IL	inspection level				
AQL	acceptable quality level				

## 7 Guidelines for the use of synthetic quartz crystal

### 7.1 General

#### 7.1.1 Overview

The guidelines have been prepared in response to a generally expressed desire on the part of both users and manufacturers for guidelines to the best use of synthetic quartz crystal. It is not the function to explain the practical techniques of manufacturing a crystal unit from quartz crystal, nor to attempt to cover all the properties of synthetic quartz crystal.

#### 7.1.2 Synthetic quartz crystal

Synthetic quartz crystals are grown by the hydrothermal temperature gradient method.

A pressure chamber (autoclave) is partially filled with the alkaline (for example, Na<sub>2</sub>CO<sub>3</sub> or NaOH) growing solution at room temperature. Seeds are placed in the upper space, and nutrient quartz fragments are placed in the bottom of the autoclave, which is then sealed and heated. The temperature in the upper space is kept lower than the

temperature at the bottom. Hence, the solute nutrient is transferred by convection currents and deposited on the seeds.

Shapes, dimensions and physical properties of grown crystals depend on the orientation and dimensions of the seeds and on growing conditions. A good control of growing processes ensures uniformity in shapes and dimensions and homogeneity in quality.

## **7.2 Shape and size of synthetic quartz crystal**

### **7.2.1 Crystal axis and face designation**

In textbooks and in national standards, differences exist in the choice of axes, handedness and axial systems for describing a quartz crystal. Figure 5a shows a quartz crystal with all the natural faces. These are not always present on synthetic quartz. Figure 5b gives the corresponding synthetic quartz faces, but since these crystals are grown from specifically oriented seeds, their physical appearance differs materially from those shown in Figures 5a and 5b.

### **7.2.2 Seed**

Several standard orientations of seeds are chosen so that the most frequently used crystal units can be economically manufactured. Crystals made from Z-cut and minor rhomb (z-minor) cut seeds are mainly for manufacturing high-frequency crystal units vibrating in thickness shear modes and medium-frequency units vibrating in face shear modes. Crystals made from Z'-cut seeds are for manufacturing low-frequency crystal units vibrating in extensional or flexural modes. A seed in a grown crystal is usually surrounded by a thin veil, which consists of bubbles and inclusions.

### **7.2.3 Shapes and dimensions**

As-grown synthetic quartz crystals are covered with the characteristic growth surfaces. Figure 6 shows the typical shape for a crystal grown on a Z-cut seed of small X-dimension. Crystals of other shapes are produced when the Z-cut seed is of other proportions or seeds of other cuts are used.

The size of synthetic quartz crystals is specified by three nominal dimensions: X, Y (or Y') and Z (or Z'). They are the dimensions along the X-axis, Y-(or Y'-) axis, and the Z- (or Z'-) axis respectively, as shown in Figure 6. The dimensions are so chosen that both economy in the growth process and good yield in the production of crystal elements may be achieved, but it should be appreciated that dimensions are a matter for discussion between the user and the manufacturer.

Since as-grown crystals exhibit such growth surfaces as m-face or z-face at the ends of the Y- or Y'-axis, the effective dimension which may be used for fabricating crystal elements is shorter than the nominal length.

An exact measurement of the minimum dimension Z' may be troublesome in practice, because of non-flatness and possible non-parallelism of the Z-surfaces. It is also difficult to achieve close dimensional tolerances. For these reasons, in cases where the user's tolerances on dimensions are closer than the manufacturer can supply, the use of partly processed material shall be considered (this is sometimes described as pre-dimensioned or lumbered quartz).

### **7.2.4 Growth zones**

Deposition of solute on each growth surface is continuous and sometimes substantially uniform, but the manner of deposition differs from zone to zone. Hence, different regions result from growth along different directions and those regions have different properties. Among the common growth zones mentioned in this standard, the Z-zone exhibits the highest quality, then the greater X-zone and S-zones follow. Hence, it is recommended

that thickness shear and face shear crystal elements should be cut entirely or mostly from the Z-zone and that only Z-zone material be included under the electrode of the finished crystal unit. The lesser X-zone exhibits the lowest quality and is usually discarded in the production of high-frequency crystal units.

Figures 3a and 3b show typical examples of cutting wafers of AT-cut plates and X-cut plates from appropriate growth zones.

### 7.3 Standard method for evaluating the quality of synthetic quartz crystal

The degree of structural and chemical imperfection of a synthetic quartz crystal depends on growth conditions, dopants used, and especially on growth rate resulting in two important practical consequences. First, the extinction coefficient  $\alpha$  of crystal may be degraded (to larger values). Second, the angle of cut to yield a certain frequency/temperature characteristic may not be uniform.

The Q-value of a crystal unit was first used as a guide to the quality of the material. A crystal unit manufactured as a 5 MHz fifth overtone frequency standard crystal resonator ensures that the Q-value reflects the internal loss but not the mounting loss and minor differences in fabrication techniques between manufacturers. The size of this crystal unit is large and sometimes impossible to cut from the Z-zone.

When coefficients of extinction,  $\alpha$ , became accepted and used for their Q-indications, they soon replaced direct Q-measurements almost completely, due to their capabilities and advantages as a characterization tool. Small growth zones can be measured, details of growth band structures can be resolved; the tests are almost non-destructive, less costly, and much quicker.

The spread of the optimum angle of cut becomes very small and comparable to the spread in natural quartz crystals, when the  $\alpha_{3500}$  is less than 0,06/cm (grade C). Hence, such crystals are recommended for the production of high-frequency crystal units having good temperature characteristics.

With good control of the growth process, uniformity of  $\alpha$ -values within one batch of production is ensured. A sample from one production batch shall include a synthetic quartz crystal having the maximum thickness along Z- or Z'-axis. A choice of this sample relates to the fact that the  $\alpha$ -values are proportional to the growth rate. Hence, the crystal with maximum thickness will have the largest  $\alpha$ -value in the batch. Hence, tests on a sampling basis will suffice for most applications.

As an additional measure for evaluating synthetic quartz, a test crystal unit is specified in the standard for testing frequency-versus-temperature characteristics. The specification for the angle of cut is so chosen that frequency-versus-temperature characteristics have linear slope and sensitive dependence on angle of cut. The specified shape and dimensions of the test element are suitable to determine an accurate angle of cut. The Q-value of this crystal unit depends considerably on the mounting and fabrication processes and should not be used to evaluate the Q of a crystal.

### 7.4 Other methods for checking the quality of synthetic quartz crystal

There are various methods for checking the structural perfection of synthetic quartz crystal, but quantitative correlations with electrical characteristics of crystal units have not been completely established. An exception is the infra-red absorption method described above, which is useful for estimating the quality.

#### 7.4.1 Visual inspection

Excessive amounts of inclusions in crystal elements should be avoided.

### 7.4.2 Infrared radiation absorption method

Some radicals, included in the crystal lattice, absorb infrared radiation at certain wave numbers. The most common impurity radical in synthetic quartz is hydrogen bonded OH, the amount of which can be estimated by the infrared extinction coefficient at a selected wave number in the range between 3 400  $\text{cm}^{-1}$  and 3 600  $\text{cm}^{-1}$ .

The concentration of OH radicals is related to the mechanical energy losses in a quartz crystal and hence there is a correlation between the absorption and the Q-value. Figure 7 shows a typical calibration curve together with measured points. A recent recalibration [26]<sup>1</sup> reports that a  $-0,01$  shift in the alpha coordinate of this curve adjusts it to yield realistic 5 MHz resonator  $Q$ s.

The infrared absorption is usually measured in the Z-zone of the crystal structure and the absorption in the lesser X-zone differs from those in the Z-zone.

It should also be noted that the infrared extinction coefficient measurement may vary, due to the choice of

- the dimensions of the window placed on the infrared beam;
- the position of the point where the measurement is made in relation to the position of the seed;
- the plane of polarization;
- the humidity and temperature environment of measurement;
- the individual infra-red spectrophotometer instrument bias.

An international Round Robin on the measurement of the infrared extinction coefficient  $\alpha$  in synthetic quartz<sup>2</sup> showed clearly that individual spectrophotometers each show a characteristic bias, which can be corrected with the use of standardized alpha quartz slices<sup>3</sup>. It is advisable to perform the correlation measurements cooperatively between the quartz supplier and user with reference to calibration slices from the Round Robin.

### 7.4.3 Miscellaneous

The chemical etch method of inspection, which is widely used for detecting twins in natural quartz, is not required in the case of synthetic quartz, where twins are very rare. The method may be used to reveal etch pits and channels as a measure of the number of dislocations. Gamma or X-ray irradiation is used for observing overall distribution of impurities. The darkening due to irradiation depends on impurity concentration and growth zone.

X-ray diffraction patterns give useful information on the perfection of crystals. The low  $\alpha$  value results in sharper Laue patterns using a divergent X-ray beam. X-ray topography by the Lang method is useful in detecting the distribution of structural defects.

However, it should be noted that all of these methods lack quantitative correlation with electrical characteristics of completed quartz crystal units.

---

<sup>1</sup> Figures between square brackets refer to the Bibliography .

<sup>2</sup> This Round Robin was conducted between 1990 and 1992 by IEC technical committee 49 (working group 5).

<sup>3</sup> For more information about this process and the availability of standard  $\alpha$ -slices, contact IEC technical committee 49 (working group 5) or a participating national committee.

## 7.5 Alpha-grade

Six grades are specified. Grades Aa, A and B are required for the highest quality crystal units. Grade C is mostly suitable for high-frequency crystal units, which require good temperature characteristics as well as low alpha-values. Grades D and E are mostly for low-frequency crystal units, for which a large size of crystal at low cost is the prime concern.

## 7.6 Optional grading (only as ordered), in inclusions, etch channels, Al content

### 7.6.1 Inclusions

Five grades are specified. Grades Ia, Ib and I are required for specific high-quality optical applications such as VCR cameras or for photolithographic processing.

Grade II is generally required for high-frequency/high-quality bulk wave or surface acoustic wave (SAW) resonators.

Grade III is relevant for most of the professional and industrial uses of quartz crystal units.

### 7.6.2 Etch channels

Six grades are specified. Grade1aa or Grade1a is required for a thick quartz sensor device that needs a chemical etching process of long period. Grades 1 and 2 are required for specified high-quality quartz crystal units, such as high-frequency fundamental or high-frequency SAW devices, or for specific processing such as chemical etching. Grade 3 is appropriate to most of the technical uses of quartz crystal units. Grade 4 is appropriate to most of the common-use quartz crystal units.

### 7.6.3 Al content

Low Al<sup>3+</sup> (a substitution impurity occupying a Si<sup>4+</sup> site) concentration also reduces the charge compensating monovalent ions that accompany Al (chiefly Na<sup>+</sup> and Li<sup>+</sup>). Control is therefore sometimes required, as when resistance to radiation darkening or frequency change is needed.

The concentration of Al is in the units of Al atoms per million Si atoms in the quartz material. The sample cleaning procedure shall not include the use of quartz etchants, to make sure that impurities are not preferentially removed by etching.

The Al content of quartz can be successfully determined by both spectrochemical methods and physical methods. The former include, in the order of their development, atomic absorption (AA), inductively coupled plasma (ICP) and direct current plasma (DCP). All these methods can also yield analysis of many metals as well as Al. They require the exercise of careful laboratory skills for accurate results, especially when the Al contents are low. The sensitivity of all is improved by predigesting the SiO<sub>2</sub> samples in HF solution (which removes the Si by the evolution of SiF gas), with the use of blank runs to control for unwanted additions of impurities from the HF used.

The physical methods include electron spin resonance (ESR), also called electron paramagnetic resonance (EPR), and infrared absorption of a swept sample at liquid nitrogen temperature. In addition, at least qualitative information can be obtained from comparisons of irradiation darkening of X-growth regions.

The spectrochemical and physical methods both involve the use of specialized equipment of such cost that it is normally installed only in laboratories expecting a volume usage of the equipment. For Al determinations in quartz, the user shall search for either a well-equipped spectrochemical laboratory with well-qualified technicians or a physical

laboratory equipped with EPR. It should be possible to obtain reasonable results from either.

Care is required in the preparation of samples for Al analysis to ensure no unwanted material is included. For example usually only one growth zone and no seed material is desired. Frequently, the desired zone is Z-growth material.

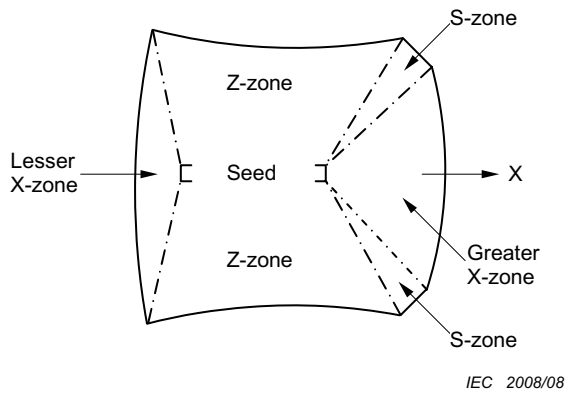
#### 7.6.4 Swept quartz

$Al^{3+} M^+$  (a monovalent charge compensating ion), defect in quartz, is transformed to  $Al^{3+} - OH$  when the alkali ion is dissociated by radiation. By this transformation, an elastic relaxation in  $Al^{3+} - M^+$  centre is erased and the elastic constant is increased. The frequency shift of quartz is triggered for this reason by radiation, but the frequency shift by radiation can be reduced if alkali ions in quartz are removed in advance by sweeping (electric field diffusion processing) to cause transformation from  $Al^{3+} - M^+$  to  $Al^{3+} - OH$  or  $Al^{3+} - e^-$ . Quartz processed through the sweeping is called swept quartz. Swept quartz is used in crystal units for satellites operating in a space radiation environment where frequency-ageing shift tends to be caused. The sweeping treatment removes the alkali ion at a high temperature by applying a high d.c. voltage to the Z-axis direction and removes the alkali ion from the quartz along the Z-axis.

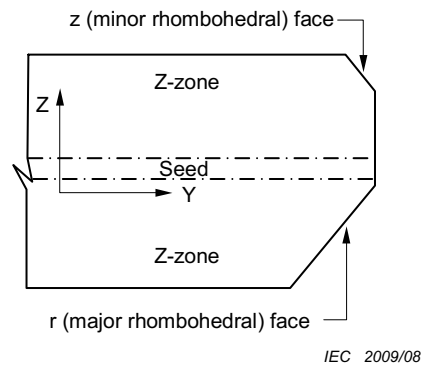
#### 7.7 Ordering

The following items shall be specified when ordering (standard grades and values shall be used whenever possible).

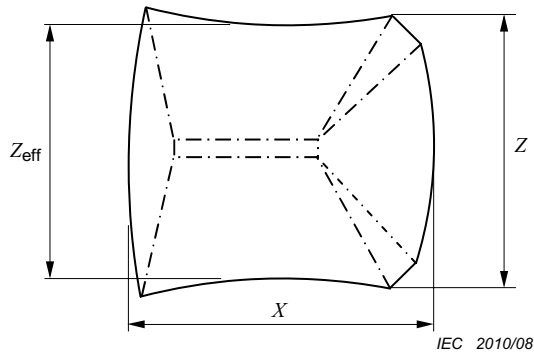
- a) As-grown synthetic quartz crystal or lumbered synthetic quartz crystal.
- b) Type of quartz (RH or LH).
- c) Orientation of seed.
- d) Dimensions.
- e) Alpha-grade.
- f) Additional grading specifications only as required.



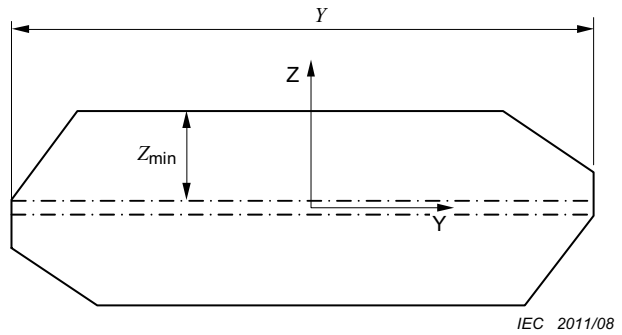
**Figure 1a – Section  $\perp$  to Y-axis**



**Figure 1b – Section  $\perp$  to X-axis**

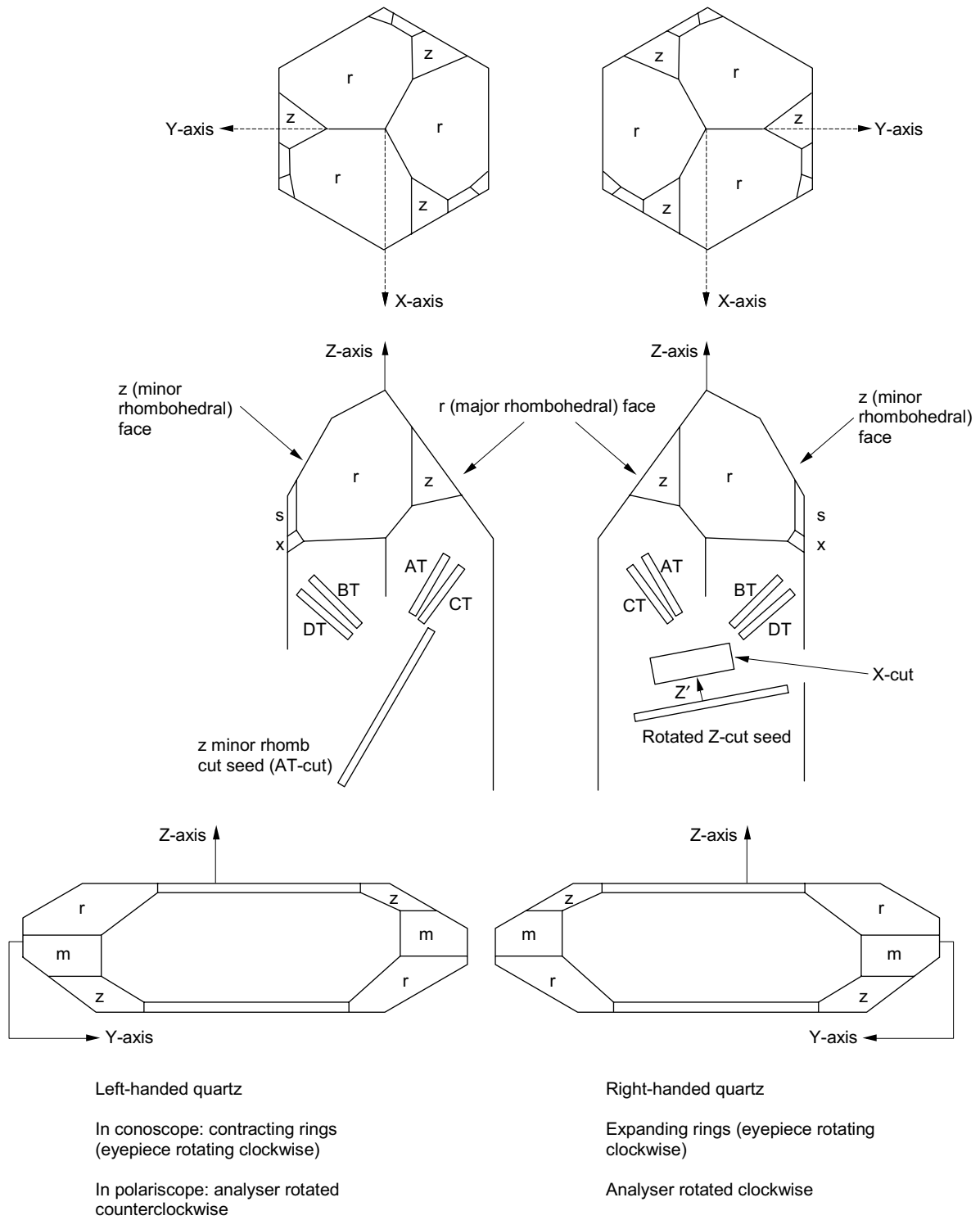


**Figure 1c – Illustration of dimensions Z and  $Z_{eff}$**



**Figure 1d – Illustration of dimension  $Z_{min}$**

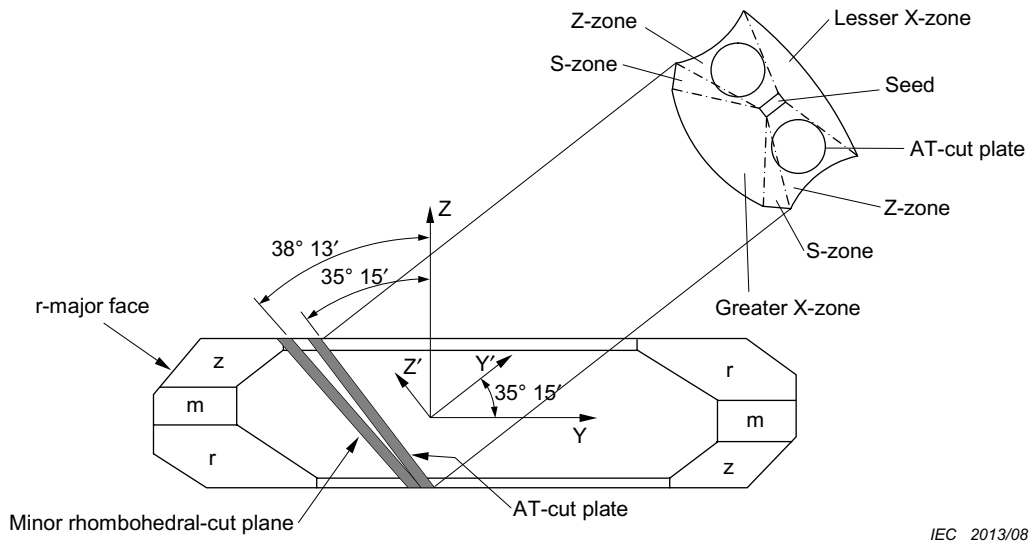
**Figure 1 – Idealized sections of a synthetic quartz crystal grown on a Z-cut seed**



IEC 2012/08

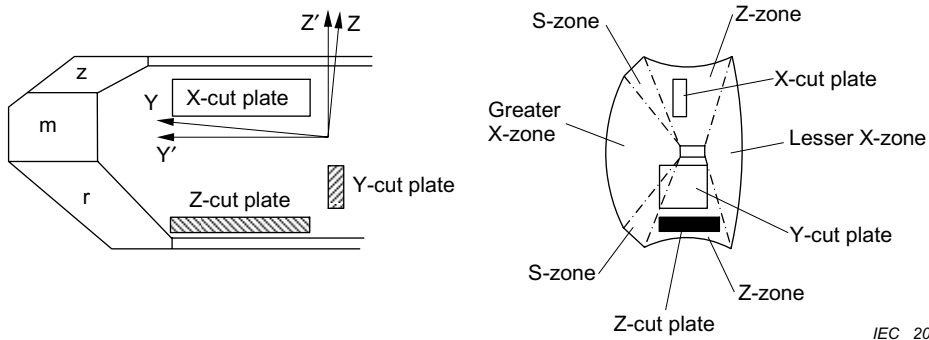
**Figure 2 – Quartz crystal axis and face designation**





IEC 2013/08

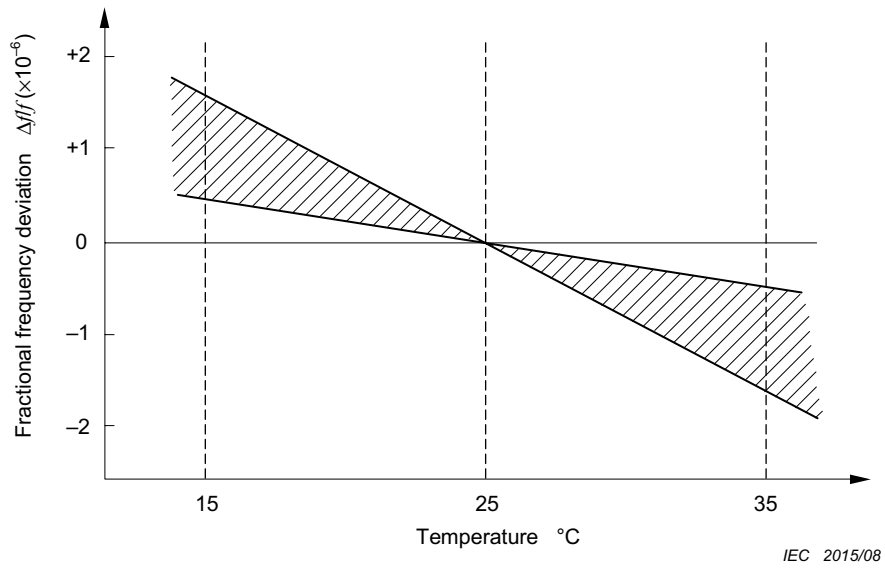
Figure 3a – Location of AT-cut plates in right-handed synthetic



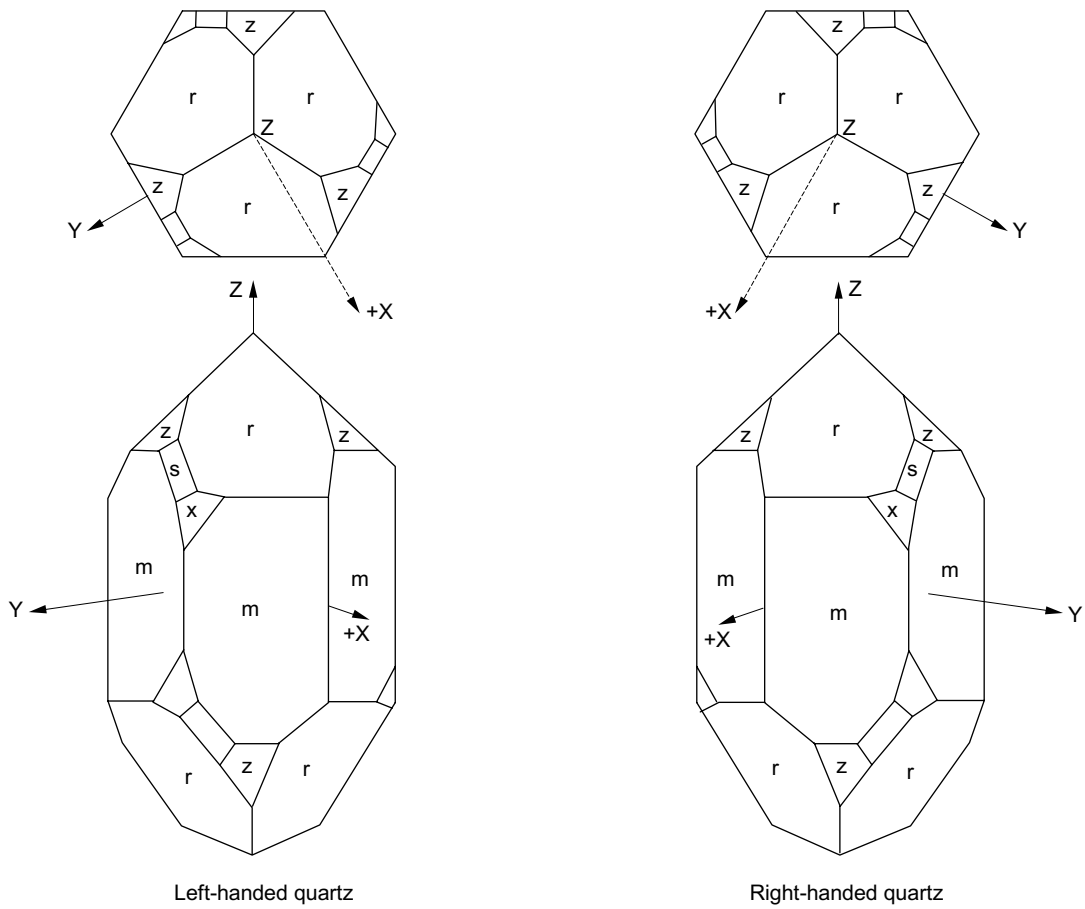
IEC 2014/08

Figure 3b – Location of X-cut plates, Y-cut plates and Z-cut plate

Figure 3 – Typical example of cutting wafers of AT-cut plate, minor rhombohedral-cut plate, X-cut plate, Y-cut plate and Z-cut plate

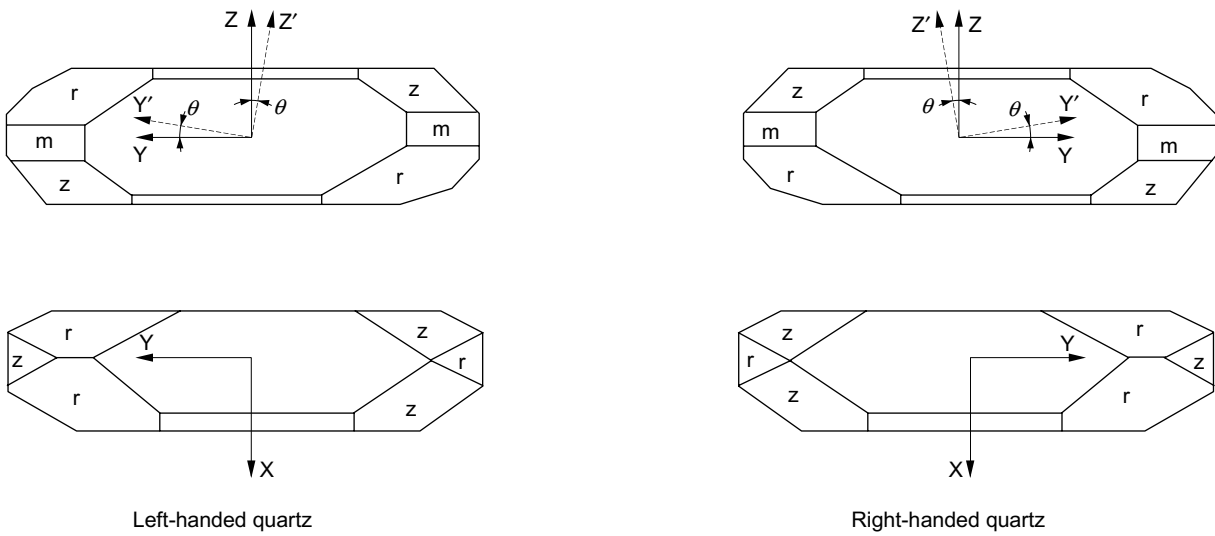


**Figure 4 – Frequency-temperature characteristics of the test specimen for slope**



IEC 2016/08

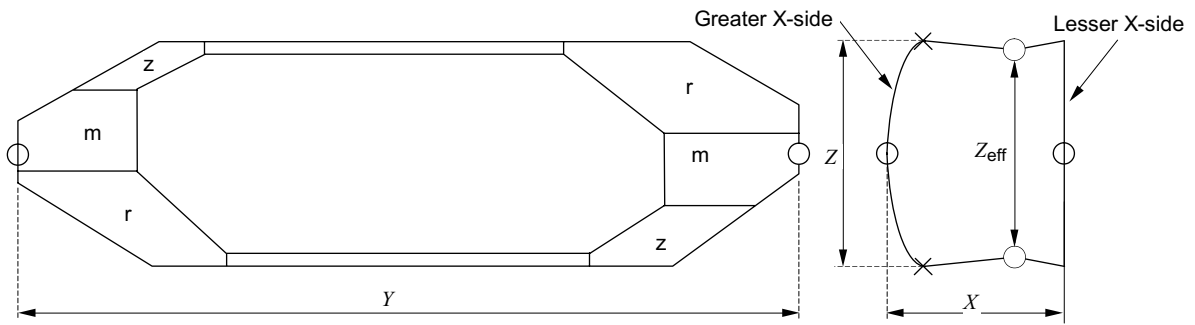
Figure 5a – Natural quartz crystals



IEC 2017/08

Figure 5b – Synthetic quartz crystals

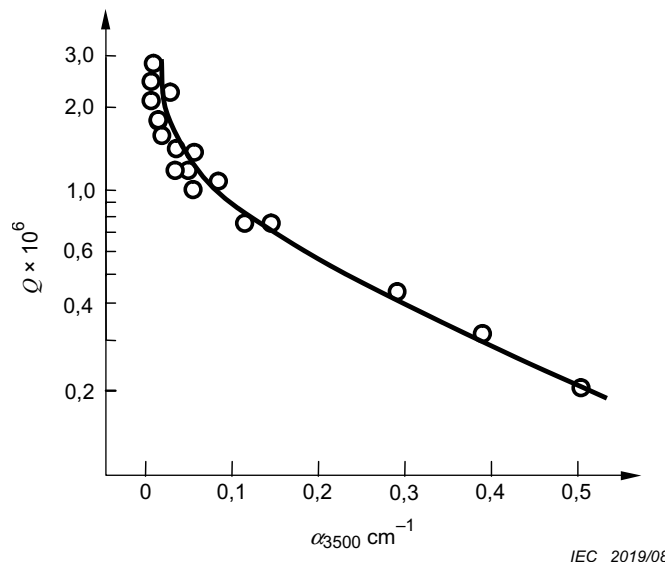
Figure 5 – Quartz crystal axis and face designation



IEC 2018/08

**Figure 6 – A synthetic quartz crystal grown on a Z-cut seed of small X-dimensions**

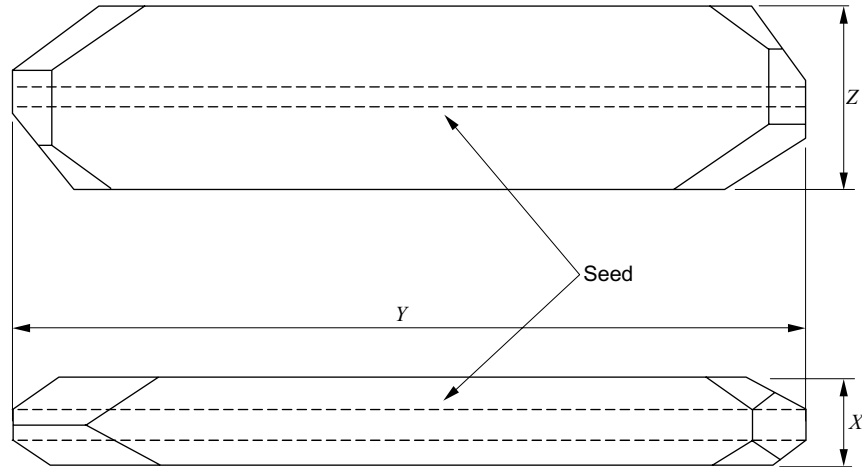
(Crystals of other shapes are produced when Z-cut seeds of other proportions, or seeds of other cuts, are used.)



IEC 2019/08

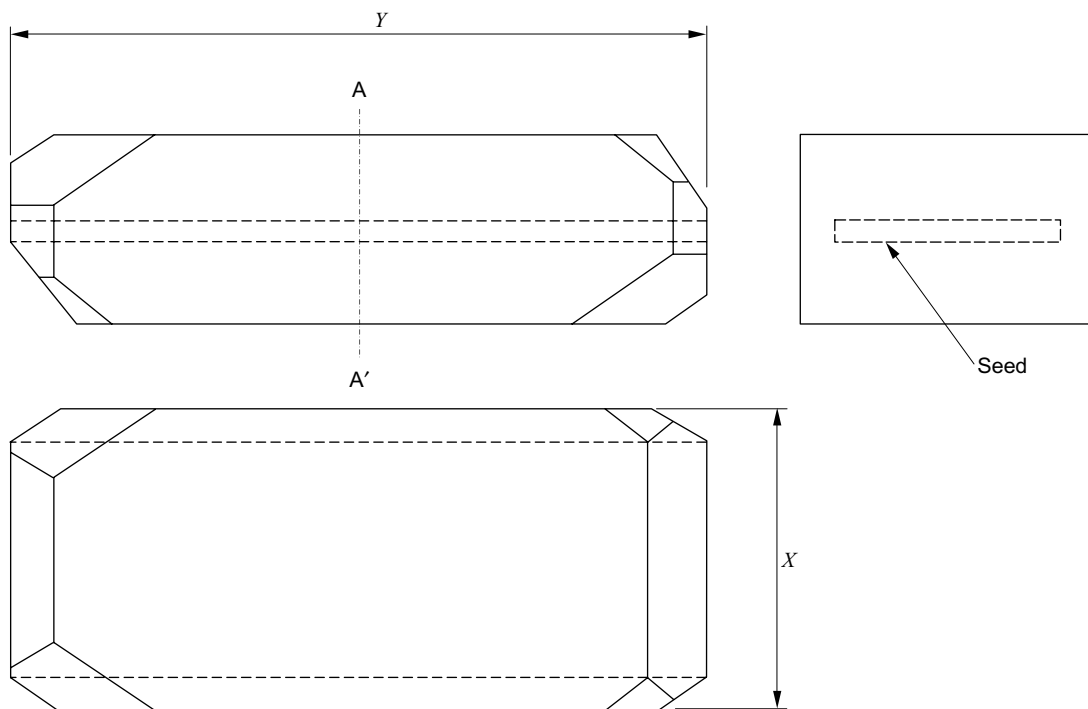
**Figure 7 – An example of an early 1970s relation between the extinction coefficient of infrared radiation and the Q-value of synthetic quartz**

(A recent recalibration of the  $Q/\alpha_{3500}$  relationship [26] concludes that for  $\alpha_{3500}$  measured on modern spectrophotometers without a beam condenser, a good approximation to realistic  $Q$ s from an old curve, such as shown here, is given by adding a 0,01  $\alpha_{3500}$  Unit adjustment to the measured  $\alpha$  and taking the  $Q$  corresponding to that sum. Although this adjustment appears small in  $\alpha$ , its effect on the  $Q$ s becomes significant in the low- $\alpha$ , high- $Q$  range.)



IEC 2020/08

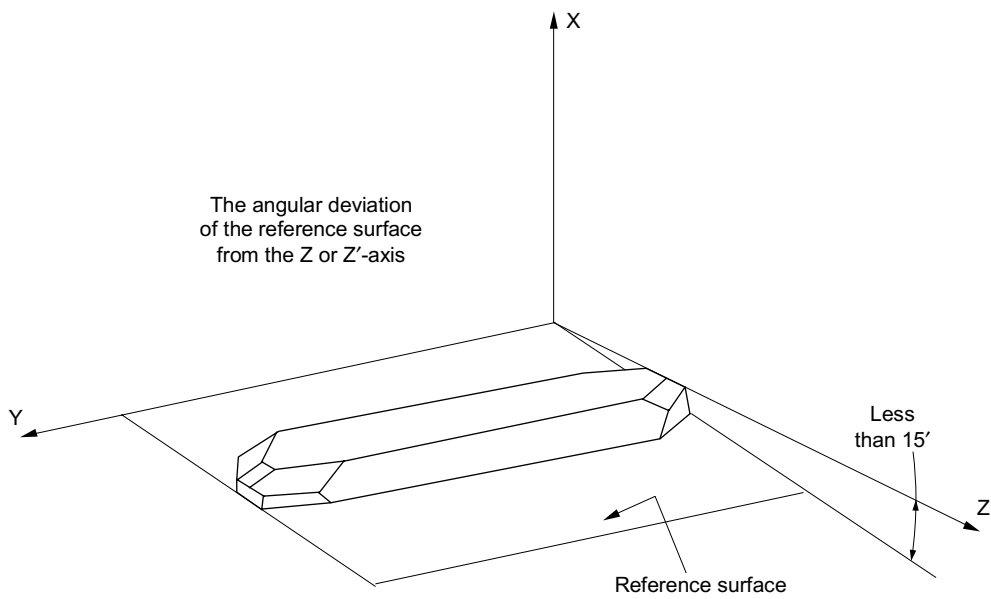
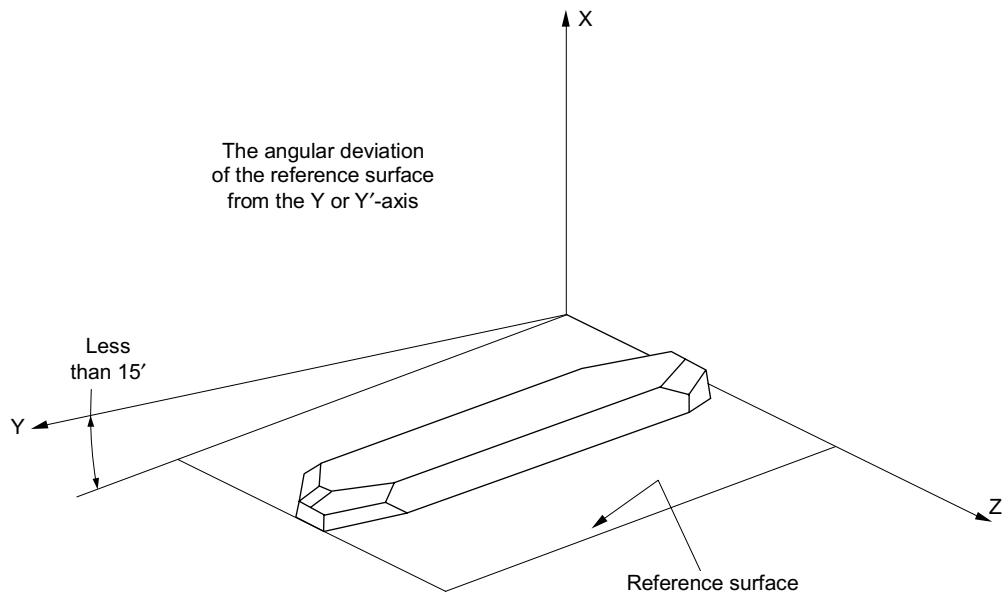
Figure 8a – Small X-dimension seed



IEC 2021/08

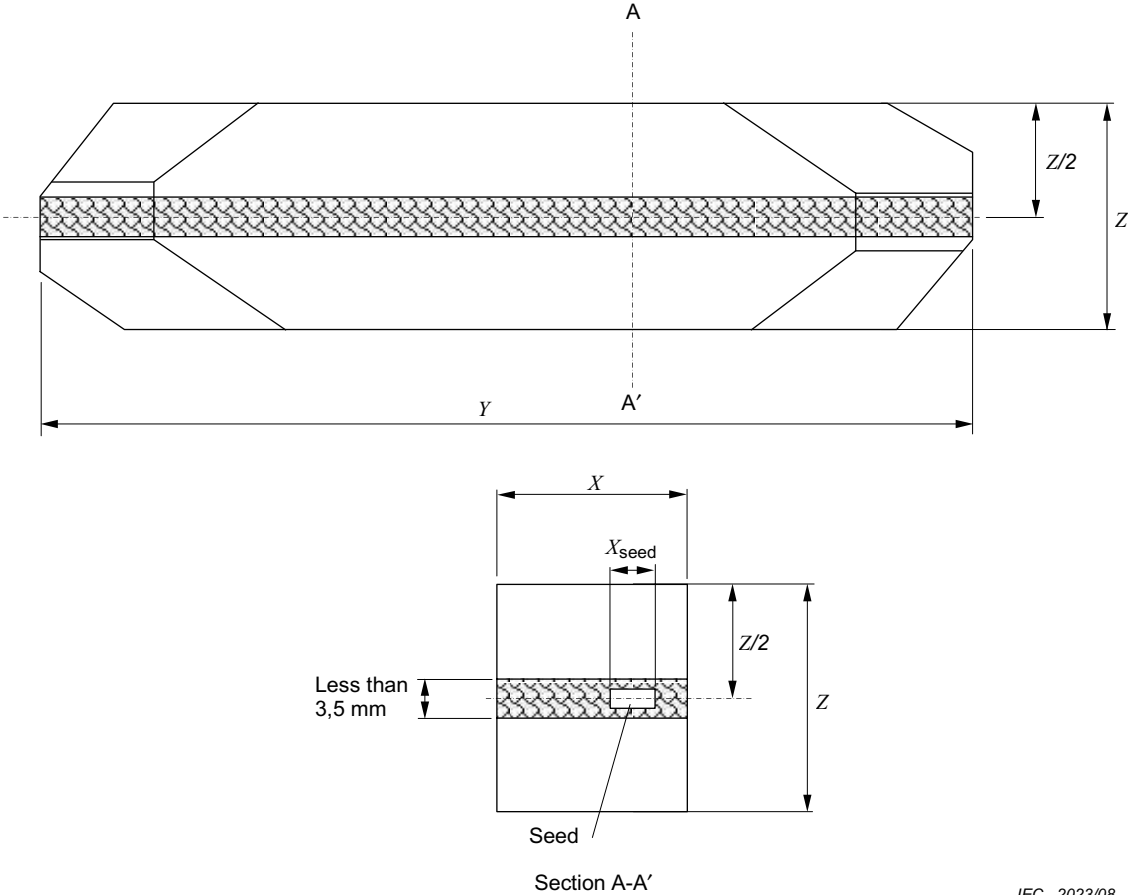
Figure 8b – Large X-dimension seed

Figure 8 – Lumbered synthetic quartz crystal outline and dimensions along X-, Y- and Z-axes



IEC 2022/08

Figure 9 – Angular deviation for reference surface



IEC 2023/08

**Figure 10 – Centrality of the seed with respect to the dimension along the Z- or Z'-axis**

## **Annex A** (informative)

### **Frequently used sampling procedures**

#### **A.1 Complete volume counting**

This method is used by both manufacturers and users for crystals to be used in applications where the inclusion density control is of prime importance.

Each crystal is inspected in accordance with the inclusion counting method described in 4.2.5.3.3, except that the total usable volume of the crystal is examined. Care should be taken to ensure that when the height of the crystal in the X-axis is larger than the focal depth of the microscope, the crystal is scanned by moving the focus over the necessary range of heights to ensure that inclusions are not missed. The number of the inclusions is recorded in each size range in the usable volume of the crystal, which is then calculated.

The inclusion density of the crystal is calculated by dividing the number of inclusions in each size category by the usable volume.

This calculated inclusion density array will be used to classify each individual crystal according to the user's requirements.

#### **A.2 Commodity Y-bar sampling – Method 1**

This method is used by both manufacturers and users for the classification of batches of Y-bars.

A sample of bars, equivalent to one or more bars per 50 kg of quartz, is selected. A higher or lower sample level may be used if higher or lower confidence levels are required, but it is recommended that a minimum of three bars per batch be used. If the test is performed by a manufacturer, the sample bars should be selected from the upper, middle and lower regions of the autoclave batch and at varying distances from the wall of the autoclave. If the test is performed by a user without batch identities, the sample should be selected at random.

The sample bars are inspected using the inclusion counting method described in 4.2.5.3.4. The number and size category of the inclusions within each of the six locations in each bar is recorded and the total volume of these sample locations calculated.

Inclusion densities for each bar are calculated by dividing the total number of inclusions in its six locations, for each size category, by their total volume.

The acceptance/rejection criteria for the batch should be co-ordinated with the sampling level used.

#### **A.3 Commodity Y-bar sampling – Method 2**

This method is used by users for the incoming inspection of high volume deliveries of Y-bars.

A random sample of 20 bars is selected from a batch. These are inspected using the inclusion counting method described in 4.2.5.3.4, except that the total usable length of



the bar is examined, but within the depth of focus of the microscope only. The user should judge the appropriateness of this method by comparing the X-height of the critical region of the device, such as its electroded area, with the depth of focus of the microscope. If the excess of the X-height is not too great, the sample taken by the microscope's focus may be sufficiently representative to be considered a reasonable sample.

The total number of inclusions ( $R$ ) in each size category is recorded.

The mean volume ( $\bar{V}$ ) for each bar is calculated using the formula:

$$\bar{V} = \frac{\left( \bar{Z} - [2 + S] \right) YD}{1000} \text{ cm}^3$$

where

$\bar{Z}$  is the mean dimension of the bar along the Z-axis, in mm;

$S$  is the width of the seed, in mm;

$Y$  is the usable length of the bar along the Y-axis, in mm;

$D$  is the depth of focus of the microscope in mm;

$\bar{Z}$  is calculated by determining the minimum and maximum dimension of each bar along the Z-axis and taking the arithmetical mean of all 40 measurements recorded.

The number of inclusions per  $\text{cm}^3$  ( $\rho$ ) is given by the formula:

$$\rho = \frac{R}{V}$$

The acceptance/rejection criteria for the batch are determined using inspection level S3 and an AQL of 1,0 % (see ISO 2859).

#### A.4 Use of comparative standards for 100 % crystal inspection

This method is widely used by manufacturers where the inclusion density varies within a production batch in and out of the acceptance density ranges, or when the desired grade requires the selection of crystals.

Each crystal is viewed in turn, the area of the crystal with the highest inclusion density being identified. This is then match-compared to one of a set of reference standards of known inclusion density. These standards may take the form of physical samples for which the density has been determined using the inclusion counting technique described in 4.2.5.3, or photographic comparison samples.

Where the inclusion density is clearly within the boundaries defined by the reference standards for a particular grade, the crystal will be classified within that grade. Where the decision is in doubt, the density being near to one of the test limits, either the crystal will be classified in the grade allowing the higher inclusion level, or a more precise determination of inclusion density using an inclusion counting technique will be performed.

A variation of this method may be automated with the use of stops on the up-and-down movement of the microscope so that it can be rapidly moved among two or three focal depth levels. In this way, more height may be sampled rapidly while scanning a bar.

**Annex B**  
(informative)

**Numerical example**

When a 30x stereo microscope, whose focal field of view measured 0,6 cm in diameter and 0,1 cm in height, was used to count inclusions at six locations over the full height within a crystal bar having an X measuring 2,0 cm, the total counts given in Table B.1 were taken.

**Table B.1 – Commodity bar sampling, method 1**

Size range μm	Number of inclusions
10 – 30	18
30 – 70	5
70 – 100	4
>100	10

The total volume counted,  $V = NH \Pi(D/2)^2$ , in this case = 3,39 cm<sup>3</sup>.

where

$N$  is the number of cylinders counted;

$H$  is the height in cm through which the microscope is lowered (in this example the bar's height);

$D$  is the field of view diameter in cm (when less than the full bar height is sampled, complete accuracy calls for letting  $H = R + h$  cm, where  $R$  is the range of microscope height traversed, and  $h$  = the height of the microscope's focal field).

Dividing each total count by 3,39 yields the four averages for the crystal bar given in Table B.2.

**Table B.2 – Commodity bar sampling**

Size range μm	Number of inclusions
10 – 30	5,3
30 – 70	1,5
70 – 100	1,2
>100	2,9

## Annex C (informative)

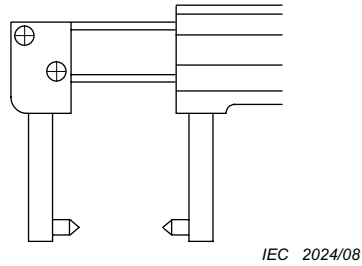
### Example of reference sample selection

Some appropriate as-grown crystal bars for a reference sample of each grade range are chosen carefully as testing bars. When the testing bars have a large X dimension seed, Y-cut slices are cut from the bars and finished to 10 mm thickness with a polished surface. Sample volumes are divided by  $1 \text{ cm}^3$  by drawing 10 mm squares on the Y surface within the Z growth zones, except the seed crystal. In the case of small X dimension ones like Y-bar, X-cut slices can be obtained by a lumbering process and finished to 10 mm thickness with a polished surface. Sample volumes are divided by  $1 \text{ cm}^3$  by drawing 10 mm squares on the X surface within Z growth zones, except the seed crystal. A drawn line that is the closest to the seed crystal shall be about 0,5 mm away from the seed surface to avoid counting the seed veil. When inclusion density changes by location in a testing bar, several slices shall be prepared to tend counts toward average density of the testing bar. Sample volumes shall be randomly chosen from prepared squares. The sample volumes shall be selected to tend counts toward average density of the slice when inclusion density changes by location in a slice. Inclusions within stated size ranges are counted in each chosen sample volume under a stereo binocular microscope operating at a magnification of 40. Counts from each sample volume are added by the stated four size ranges, and averaged by the total chosen sample volumes within a slice. If several slices are prepared from a testing bar, counts shall be averaged by all slices. An average count for each size range measured by the above-mentioned method is regarded as the evaluation-count of the testing bar. The reference sample shall be selected as having an evaluation-count that is closest to the boundary of each grade.

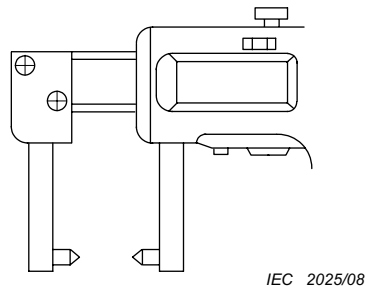
## Annex D (informative)

### Explanations of point callipers

Point callipers have two extended measuring points as shown in Figures D.1 and D.2 suitable for measuring samples with irregular surfaces such as observed on the Z-faces of as-grown synthetic quartz.



**Figure D.1 – Point callipers**



**Figure D.2 – Digital point callipers**

## **Annex E** (informative)

### **Infrared absorbance alpha value compensation**

#### **E.1 General**

It is well known that alpha values measured in different laboratories using the procedures recommended in this standard and using similar equipment to each other result in measurements with deviations between laboratories beyond the limits of accuracy required to assure conformance to the alpha requirements of this standard. To address this issue and to establish correlation between laboratories, a Round Robin was conducted involving five (5) samples with a wide range of alpha values and over twenty (20) laboratories. A procedure to establish correction terms based on the differences between individual results and the averages across laboratories at constant wave numbers and samples was established. The same methods described in this annex may be applied to establish correction terms in the future. The Round Robin included grating based IR spectrophotometers using a double-beam configuration and FTIR equipment, thus allowing the process to be applied to equipment using either measuring method.

#### **E.2 Sample preparation, equipment set-up and measuring procedure**

To reduce the variation between laboratories a set of recommendations concerning sample preparation, equipment set-up, and measuring procedure is described.

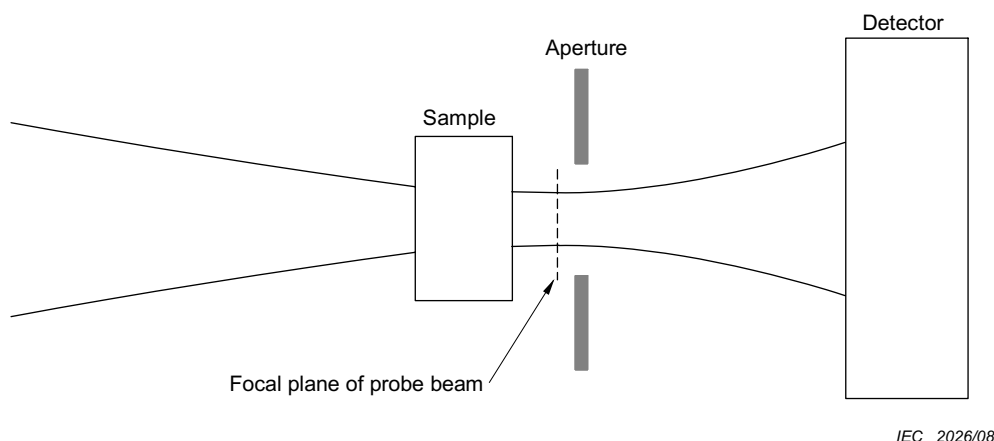
##### **E.2.1 Sample preparation**

The suggested sample preparation procedure is as follows:

- sample cut from the Z-zone, not including any portion of the seed;
- light propagation is along the Y-axis. Y-faces are polished to a state commonly referred to as "optical inspection grade";
- the thickness (Y) should be 10 mm  $\pm$ 0,2 mm. The dimensions for X and Z should be as convenient and established in consideration of the measuring aperture;
- the angular deviation of the surface normal on the X and Y faces is less than 30' from the corresponding crystal axis;
- the X and Z faces are ground to a roughness achieved by mesh #80 diamond grit or rougher.

##### **E.2.2 Equipment set-up**

A diagram of the usual instrument configuration is shown in Figure E.1 .



**Figure E.1 – Schematic of measurement set-up**

The sample is positioned so that the beam exit surface is within 5 mm of the focal plane and the focal plane is between the test sample and the aperture.

The instrument settings (scan speed of FTIR, slit width in grating spectrometer) should ensure that the wavelength resolution is about  $6,0 \text{ cm}^{-1} \pm 0,5 \text{ cm}^{-1}$ .

The aperture size is  $12 \text{ mm} \times 2 \text{ mm}$ . The 12 mm dimension is along the crystal X direction.

The aperture is positioned between the sample and the focal plane in such a way that the transmission is maximized at the reference wave number.

With the sample removed, the instrument is calibrated to read 100 % transmission at all reference and absorption wave number settings.

The reference wave numbers are  $3\,800 \text{ cm}^{-1} \pm 3 \text{ cm}^{-1}$  and  $3\,979 \text{ cm}^{-1} \pm 3 \text{ cm}^{-1}$ .

The absorption wave numbers are  $3\,500 \text{ cm}^{-1} \pm 3 \text{ cm}^{-1}$ ,  $3\,585 \text{ cm}^{-1} \pm 3 \text{ cm}^{-1}$ , and  $3\,410 \text{ cm}^{-1} \pm 3 \text{ cm}^{-1}$ . The absorption wave number setting for the  $3\,585 \text{ cm}^{-1}$  measurement should be adjusted to achieve the local minimum value of transmission.

The measurement temperature is  $15 \text{ }^\circ\text{C} - 25 \text{ }^\circ\text{C}$ .

The measurement relative humidity is 70 % or less.

### **E.2.3 Measurement procedure**

Uncorrected absorbance values at any of the three absorption wave numbers are calculated by using the formula in 3.18.  $T_1$  is evaluated at the same reference wave number that was used to establish the calibration terms described in Clause E.3. In a grating spectrometer, the measurements should be made without scanning the wave number. The samples should have the beam centred inside the aperture. Consistent positioning of the samples can be achieved with dedicated sample-holders.

### E.3 Procedure to establish correction terms

The procedure to establish correction terms is performed independently for any of the three absorption wave numbers, and the example here should only discuss the case of  $3\ 500\ \text{cm}^{-1}$ . The samples used for the Round Robin or an equivalent set of samples are measured as described in E.2.2 and E.2.3.

An example of the calibration method is shown below. A set of five (5) standard samples was tested by several laboratories and an average of uncorrected data determined (inclusive of all instruments) at the three wave number combinations and labelled "averaged" in Tables E.1 to E.3. The measurements of one laboratory are shown and labelled "measured".

**Table E.1 – Example of calibration data at  $\alpha\ 3585$**

Averaged	Measured
0,0157	0,0155
0,0382	0,0373
0,0624	0,0591
0,1555	0,1538
0,1362	0,1378

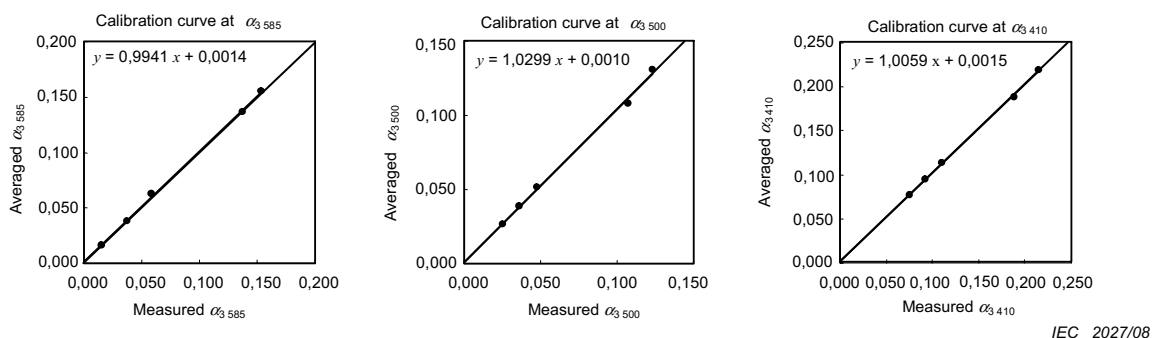
**Table E.2 – Example of calibration data at  $\alpha\ 3500$**

Averaged	Measured
0,0261	0,0251
0,0383	0,0361
0,0514	0,0475
0,1306	0,1232
0,1077	0,1072

**Table E.3 – Example of calibration data at  $\alpha\ 3410$**

Averaged	Measured
0,0770	0,0756
0,0942	0,0921
0,1139	0,1105
0,2148	0,2148
0,1888	0,1888

This data is graphically shown in Figure E.2 with the corresponding least square fit of a linear approximation.



**Figure E.2 – Graph relationship between averaged alpha and measured alpha at three wave numbers of  $\alpha_{3500}$ ,  $\alpha_{3585}$  and  $\alpha_{3410}$**

The calibration terms calculated in these three examples are factor  $a = 1,0299$  and offset  $b = +0,0010 \text{ cm}^{-1}$  at  $\alpha_{3500}$ ,  $a = 0,9941$  and offset  $b = +0,0014$  at  $\alpha_{3585}$ , and  $a = 1,0059$  and offset  $b = +0,0015$  at  $\alpha_{3410}$ .

#### E.4 Calculation of compensated (corrected) absorbance values

After the correction terms are known for the measurement set-up and wavelength of interest, the sample to be evaluated is measured according to E.2.3. The corrected absorbance value  $\alpha^{\text{corrected}}$  is calculated from the uncorrected measurement  $\alpha$  using the following formula and the correction terms  $a$  and  $b$  as defined in Clause E.3.

$$\alpha^{\text{corrected}} = a \alpha + b$$



## Annex F (informative)

### The differences of the orthogonal axial system for quartz between IEC standard and IEEE standard

IEEE revised IEEE Standard 176-1946 in 1978 and revised it again to issue it as IEEE Standard 176-1987 in 1987. The main revision point is the +X inversion of orthogonal crystal axis shown in Figure 1 and it is different from that of the present IEC 60758.

The differences between IEEE Standard 176-1987 and IEC 60758 are given below.

- a) Right-handed quartz is expressed by the right-handed orthogonal axial system, also left-handed quartz is expressed by the left-handed orthogonal axial system in IEC 60758. However, the right-handed orthogonal axial system is applied for right-handed and left-handed quartz in IEEE Standard 176-1987.
- b) For right-handed quartz, the relation between IEC 60758 and IEEE Standard 176-1987 is that of rotated 180 degrees around the Z-axis. For left-handed quartz, the relation between IEC standard 60758 and IEEE Standard 176-1987 is that of reversed Y-axis.
- c) All material constant values of left-handed quartz are the same as the material constant values of right-handed quartz in IEC standard 60758. In IEEE Standard 176-1987, however, elastic constant of right-handed quartz and left-handed quartz are the same, but the plus or minus sign of the piezoelectric constant is reverse to each other.
- d) In IEC 60758, the elastic constant of  $C_{14}$  is a negative quantity and the piezoelectric constant of  $e_{11}$  is a negative value and that of  $e_{14}$  is a positive value. On the other hand, in IEEE Standard 176-1987, all these quantities, that is,  $C_{14}$ ,  $e_{11}$  and  $e_{14}$ , are positive values.
- e) According to IEC 60758, for example AT-cut at right-handed quartz is called +35° rotated Y-cut. However, according to IEEE Standard 176-1987, it should be called –35° rotated Y-cut.

Now, in all international academic papers, quartz material constants are written based on IEEE Standard 176-1987. Care should be taken to avoid confusion which may be caused by the expression differences of material constants and crystal axes between IEEE 176-1987 and IEC 60758.

ANSI/IEEE Std 176-1987

©1987 IEEE

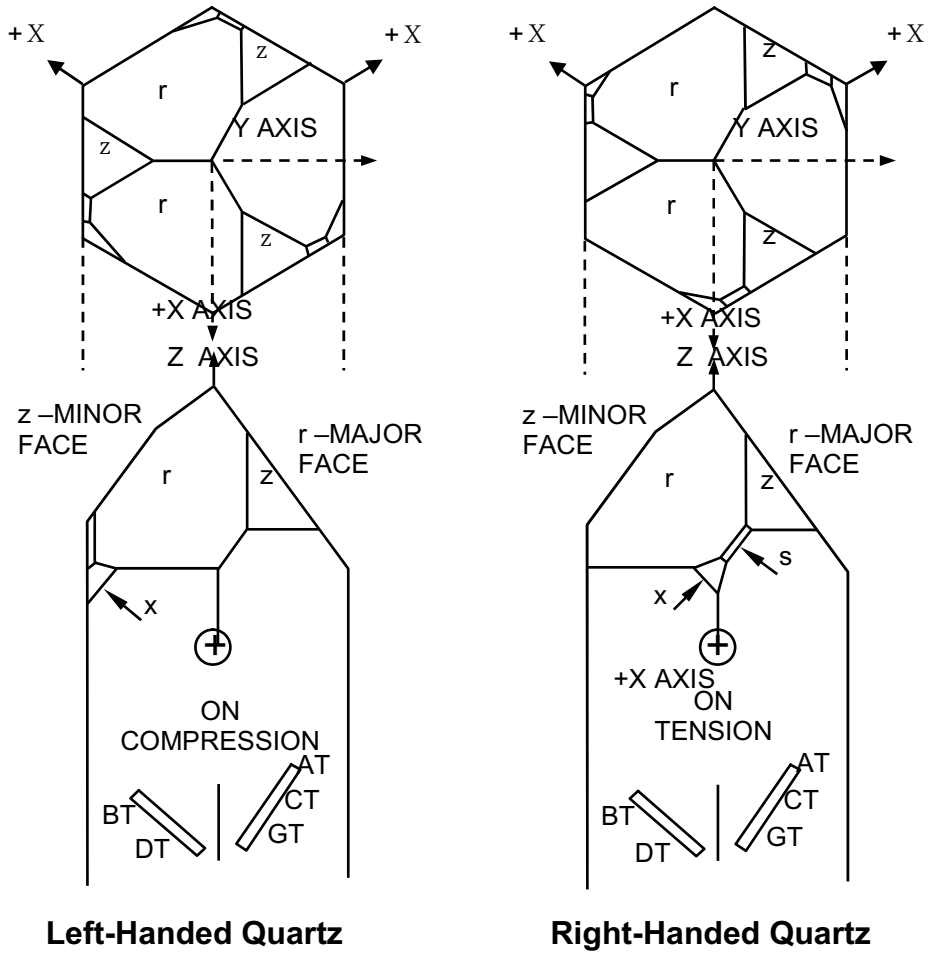


Figure F.1 – Left- and right-handed quartz crystals

## Bibliography

### General

- [1] R.A. Laudise and J.W. Nielsen: Hydrothermal Crystal Growth (Academic Press Inc.: Solid State Physics, v. 12, p. 149).
- [2] W.J. Spencer: Observation of Resonant Vibrations and Defect Structure in Single Crystals by X-ray Diffraction Topography (Academic Press: Physical Acoustics, v. 5, p. 111).
- [3] D.B. Fraser: Impurities and Anelasticity in Crystalline Quartz (Academic Press: Physical Acoustics, v. 5, p. 59).

### Specialized

- [4] IEC 60122-2: Quartz Crystal Units for Frequency Control and Selection, Part 2: Guide to the Use of Quartz Crystal Units for Frequency Control and Selection, 1983.
- [5] A.C. Walker: Hydrothermal Growth of Quartz Crystals (Ind. Eng. Chem., v. 46, p. 1670, 1954) .
- [6] D.L. Wood: Infrared Absorption of Defects in Quartz (J. Phys. Chem. Solids, v. 13, p. 326, 1960).
- [7] C.S. Brown: Internal Friction in Synthetic Quartz (Proc. Phys. Soc., v. 75, p. 459, 1960).
- [8] F. Augustine and D.R. Hale: Topography and Etch Patterns of Synthetic Quartz (J. Phys. Chem. Solids, v. 13, p. 334, 1960).
- [9] J.W. Nielsen and F.G. Foster: Unusual Etch Pits in Quartz (Amer. Mineral, v. 45, p. 299, 1960) .
- [10] S.V. Starodubtsev, Sh. Vakhidov and L.1. Tsinober: Sector Distribution of Luminescence Centres in Synthetic Quartz (Kristallografia, v. 8, p. 770, 1964. In Russian).
- [11] L.1. Tsinober and I.E. Kamentsev: Effect of Growth Rate on the Concentration of Centres of Smoky Colour and on the Unit Cell Parameters of Synthetic Quartz Crystals (Kristallografia, v. 9, p. 448, 1964. In Russian).
- [12] A.A. Ballman and D.W. Rudd: The Growth of Cultured Quartz (Western Electric Engineer, v. 9, p. 3, 1965).
- [13] D.M. Dodd and D.B. Fraser: The 3 000-3 900  $\text{cm}^{-1}$  Absorption Bands and Anelasticity in Crystalline  $\alpha$ -Quartz (J. Phys. Chem. Solids. v. 26, p. 673, 1965).
- [14] D.W. Rudd, E.E. Houghton and W.J. Carrol: Mechanical Q of Alpha-Quartz Rapidly Evaluated (Western Electric Engineer, v. 10, p. 22, 1 966). [15] W.J. Spencer and K. Haruta: Defects in Synthetic Quartz (J. Appl. Physics, v. 37, p. 549, 1966).
- [16] A.R. Lang and V.F. Miuskov: Dislocation and Fault Surface in Synthetic Quartz (J.Appl. Phys., v. 38, p. 2477, 1967).
- [17] G. Matsuki and F. Iwasaki: Hydrogen Bonded OH in Synthetic Quartz (Japan, J. Appl. Phys., v. 7, p. 1 136, 1968).
- [18] I. Koga: Specifying Quartz Crystal Cuts without Regard to Handedness (Proc. IEEE, v. 57, No. 12, 1969, p. 2171).
- [19] B. Sawyer: Q Capability Indication from Infrared Absorption Measurements for  $\text{Na}_2\text{CO}_3$  Processed Cultured Quartz (IEEE Trans. Sonics and Ultrasonics, v. SU-19, p. 41, 1972).
- [20] N.C. Lias, E.E. Grudenski, E.D. Kalb and R.A. Laudise: The Growth of High Acoustic Q Quartz at High Growth Rates (J. Crys. Growth, v. 18, p. 1 , 1973).
- [21] J. Asahara, E. Yazaki, K. Takazawa and K. Kita: Influences of the Inclusions in Synthetic Quartz (Proc. 29th Ann. Freq. Control Symp., p. 21 1 , 1975).

- [22] J.C. Brice and A.M. Cole: The Characterization of Synthetic Quartz by Using Infrared Absorption (Proc. 32nd Ann. Freq. Control Symp., p. 1 , 1978).
- [23] J.F. Balascio and N.C. Lias: Standard Characterization Methods for the Determination of the Quality of Hydrothermally Grown Quartz (Proc. 37th Ann. Freq. Control Symp., p. 1 57, 1983) .
- [24] M. Ikeda, M. Kurashige, S. Maeda, Y. Mikawa, K. Nagai, J. Takahashi, H. Takashima, M. Kyono, N. Yamamoto: Study and Proposal of Alpha-Grade Evaluation Procedure for Synthetic Quartz Crystal (Proc. 54th Ann. Freq. Control Symp., p. 206, 2000).
- [25] J.C. Brice: Crystals for Quartz Resonators (Reviews of Modern Physics, v. 57, No. 1, p. 105, 1985).
- [26] B. Sawyer: Quality Indications from Infrared Absorption Measurements on Cultured Quartz (IEEE Trans. on Ultrasonics, Ferroelectrics and Frequency Control, p. 558, 1987).
- [27] J.J. Martin: Electrodiffusion (Sweeping) of Ions in Quartz - a Review (IEEE Trans. on Ultrasonics, Ferroelectrics and Frequency Control, p. 228, 1 988).
- [28] J.G. Gualtieri and K.L. Blisnuk: Spurious Surface Finish Improvement of the Infrared Extinction Coefficient of Alpha Quartz. (IEEE Trans. on Ultrasonics, Ferroelectrics and Frequency Control, p. 494, 1991).
- [29] B. Sawyer: International Round Robin in Infrared Alpha Measurements on Slices of Synthetic Quartz (IEEE Trans. on Ultrasonics, Ferroelectrics and Frequency Control, p. 467, 1994).

---



INTERNATIONAL  
ELECTROTECHNICAL  
COMMISSION

3, rue de Varembé  
PO Box 131  
CH-1211 Geneva 20  
Switzerland

Tel: + 41 22 919 02 11  
Fax: + 41 22 919 03 00  
[info@iec.ch](mailto:info@iec.ch)  
[www.iec.ch](http://www.iec.ch)